



## **Moulding Catalog**

Phone: 404-699-8661 | Fax: 404-699-8662

4415 Wendell Dr SW | Atlanta, GA 30336  
[www.vintagemillworkga.com](http://www.vintagemillworkga.com)



# About Us

Vintage Millwork is a family owned and operated moulding, millwork and pocket door frame manufacturer located in Atlanta, GA. Established in 1974, the company originally focused solely on the dentil moulding and pocket door frame industry, where it became an industry leader with quality products shipping all over the United States on a daily basis. The company added a moulder in the 1990's and shifted more focus onto the custom architectural mouldings that we continue to offer today. After some down years, Jay Patel purchased the company in 2007 hoping to bring renewed vigor to the Vintage Millwork brand. During the economic downturn of the late 2000's, the company was moved to its location today. Vintage Millwork is located off of I-20, I-285 and Fulton Industrial Blvd - we believe our strategic location as a premier moulding manufacturer located near the interchange of two major interstates in the greater Atlanta area allows us to effectively serve customers throughout the state and region.

Our specialty is in the manufacturing of both standard and custom mouldings in any desired species without minimum run quantities. We also continue to offer our industry-leading dentil mouldings and pocket door frames. We hope we can provide our products for you so please look through our catalog to learn more of what we can offer. Please do keep in mind that these are just a fraction of what we can offer – the profiles contained within these pages simply represent the architectural foundation of homes across Atlanta and the Southeast that have been gathered over the years. With our in-house knife grinding machine, we can match existing mouldings or drawings and furnish products within a matter of days. For more details, please contact us directly. As a family owned company, we pride ourselves on our quality and customer service. We would like to thank you for taking the time to learn a little more about us and hope to hear from you soon.

# Contents

<b>Crown Moulding</b> .....	<b>Pages 6 - 11</b>
<b>Cove Crown</b> .....	<b>Pages 12 - 13</b>
<b>Dentil Crown</b> .....	<b>Pages 14 - 15</b>
<b>Dentil Moulding</b> .....	<b>Page 16</b>
<b>Base Board</b> .....	<b>Pages 17 - 20</b>
<b>Casing</b> .....	<b>Pages 21 - 28</b>
<b>Plinth Block</b> .....	<b>Pages 29 - 31</b>
<b>Back Band</b> .....	<b>Pages 32 - 33</b>
<b>Mull Casing</b> .....	<b>Page 34</b>
<b>Pilaster</b> .....	<b>Page 35</b>
<b>Chair Rail</b> .....	<b>Pages 36 - 39</b>
<b>Apron</b> .....	<b>Page 40</b>
<b>Picture Mould</b> .....	<b>Page 41</b>
<b>Panel Mould</b> .....	<b>Pages 42 - 43</b>
<b>Stop</b> .....	<b>Page 44</b>
<b>Cove Mould</b> .....	<b>Page 45</b>
<b>Base Cap</b> .....	<b>Page 46</b>
<b>Shoe Mould</b> .....	<b>Page 47</b>
<b>Quarter Round</b> .....	<b>Page 48</b>
<b>Half Round</b> .....	<b>Page 49</b>
<b>Full Round</b> .....	<b>Page 50</b>
<b>Capital Mould</b> .....	<b>Page 51</b>
<b>Base Mould</b> .....	<b>Page 52</b>
<b>Corner/Pencil Mould</b> .....	<b>Page 53</b>
<b>Cabinet Mould</b> .....	<b>Page 54</b>

# Contents

<b>Clover Mould .....</b>	<b>Page 55</b>
<b>Miscellaneous .....</b>	<b>Page 56</b>
<b>Window Stool .....</b>	<b>Pages 57 - 58</b>
<b>Hand Rail .....</b>	<b>Pages 59 - 60</b>
<b>Bar Rail .....</b>	<b>Page 61</b>
<b>Mantel Mould .....</b>	<b>Page 62</b>
<b>Box Cornice .....</b>	<b>Page 63</b>
<b>Drip Cap .....</b>	<b>Page 64</b>
<b>Brick Mould .....</b>	<b>Page 65</b>
<b>Rake .....</b>	<b>Page 66</b>
<b>Threshold .....</b>	<b>Page 67</b>
<b>T-Strip .....</b>	<b>Page 68</b>
<b>Reducer .....</b>	<b>Page 69</b>
<b>Nosing/Tread.....</b>	<b>Pages 70 - 71</b>
<b>S4S Lumber .....</b>	<b>Page 72</b>
<b>Paneling.....</b>	<b>Page 73</b>
<b>Index.....</b>	<b>Pages 74 - 76</b>

Please visit our website for any additional mouldings.

[www.vintagemillworkga.com](http://www.vintagemillworkga.com)

# Crown

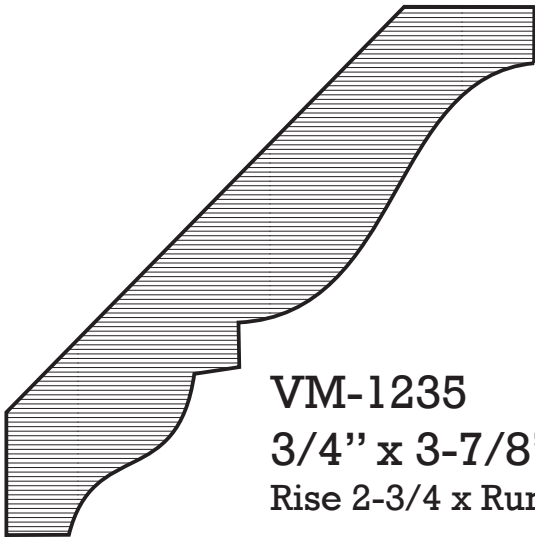

VM-1235  
3/4" x 3-7/8"  
Rise 2-3/4 x Run 2-3/4

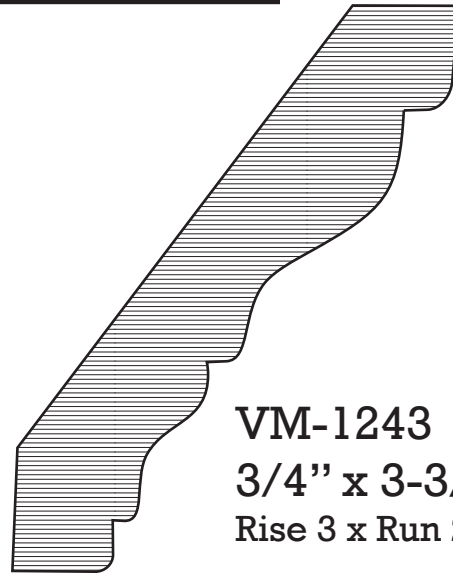

VM-1243  
3/4" x 3-3/4"  
Rise 3 x Run 2-5/16

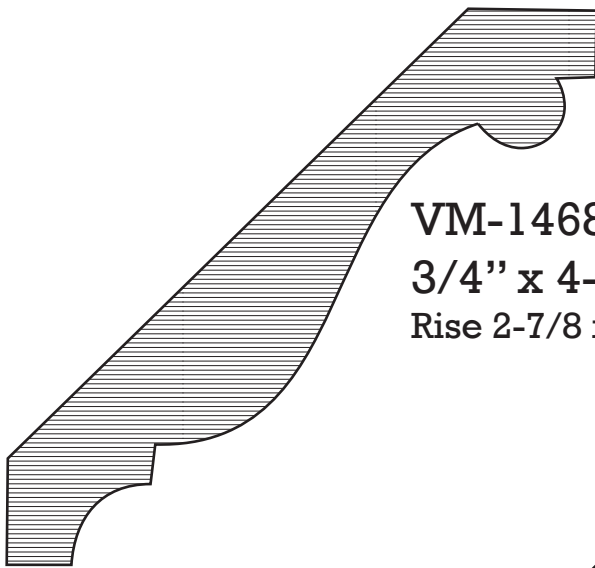

VM-1468  
3/4" x 4-3/16"  
Rise 2-7/8 x Run 3-1/16

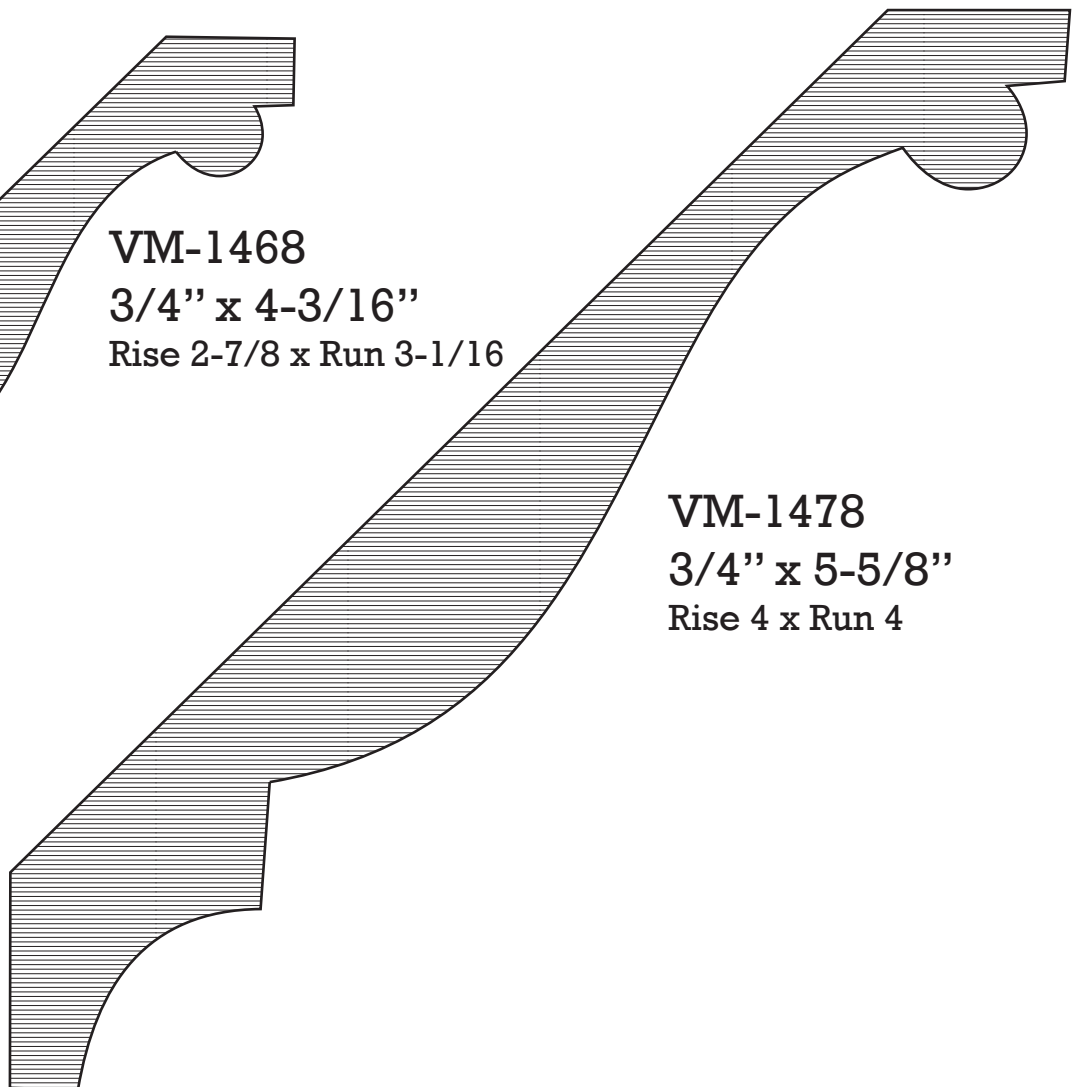

VM-1478  
3/4" x 5-5/8"  
Rise 4 x Run 4

# Crown

VM-1894

3/4" x 3-1/2"

Rise 2-9/16 x Run 2-1/4

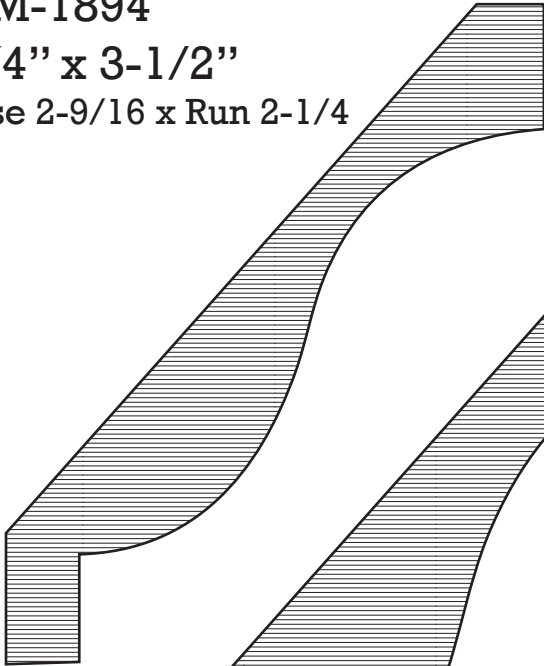

VM-1896

7/8" x 5-1/4"

Rise 4-1/4 x Run 3-3/8

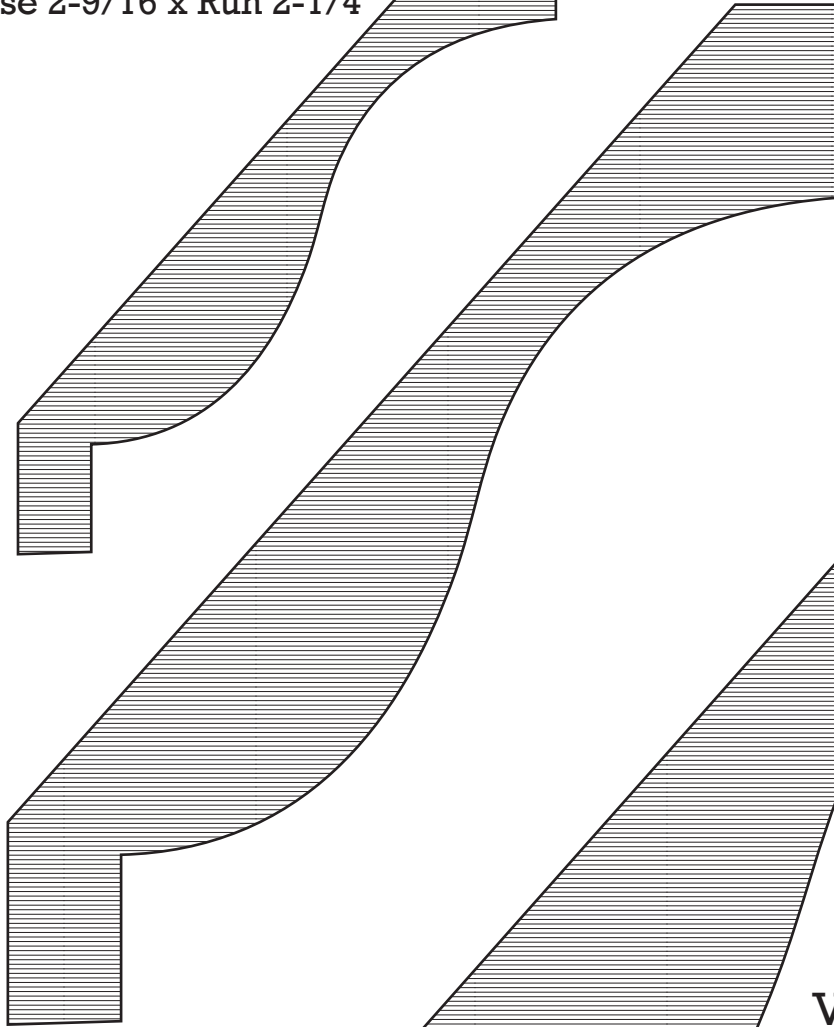

VM-1897

1 1/4" x 6-5/8"

Rise 5-1/8 x Run 4-1/2

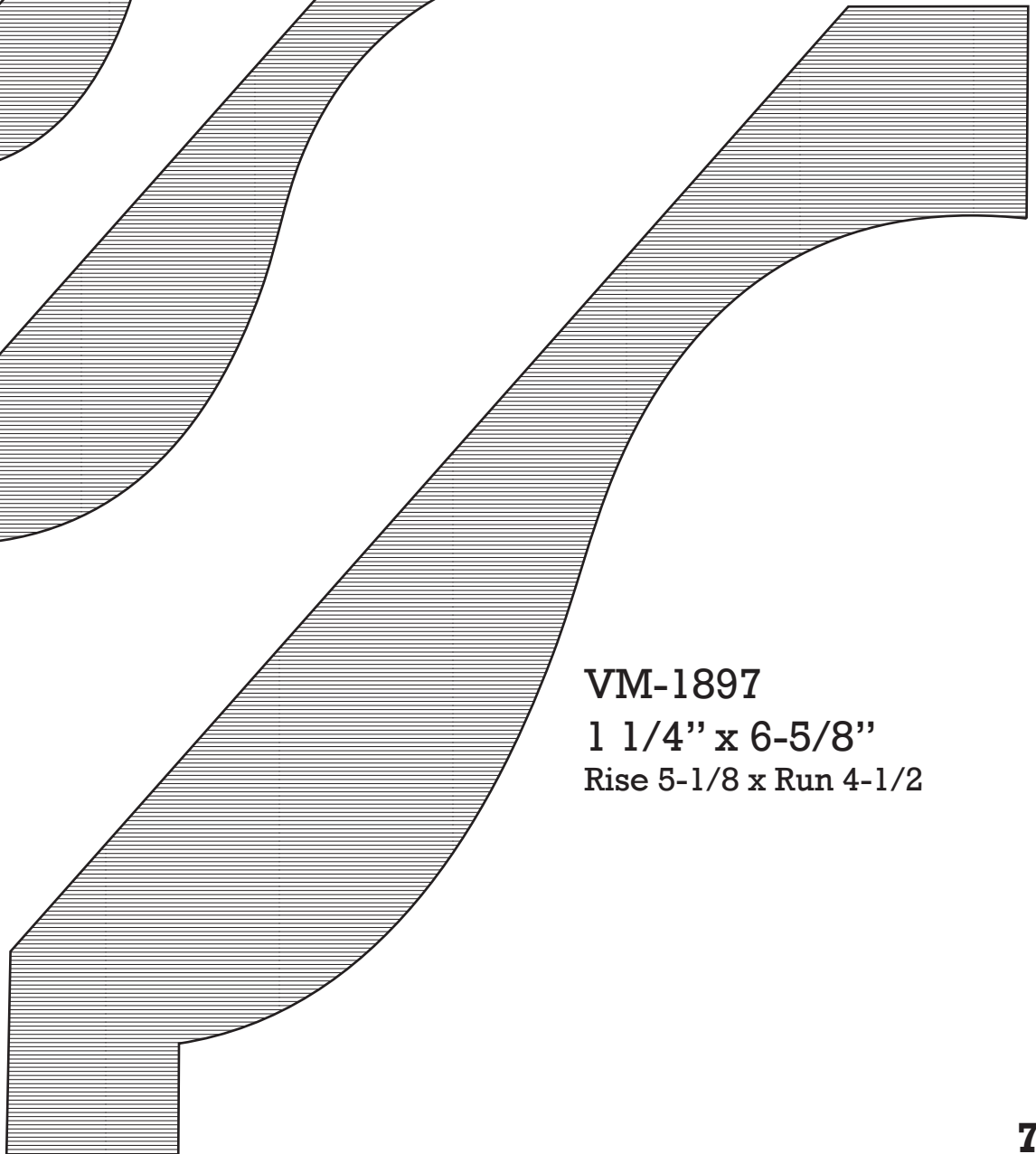

# Crown

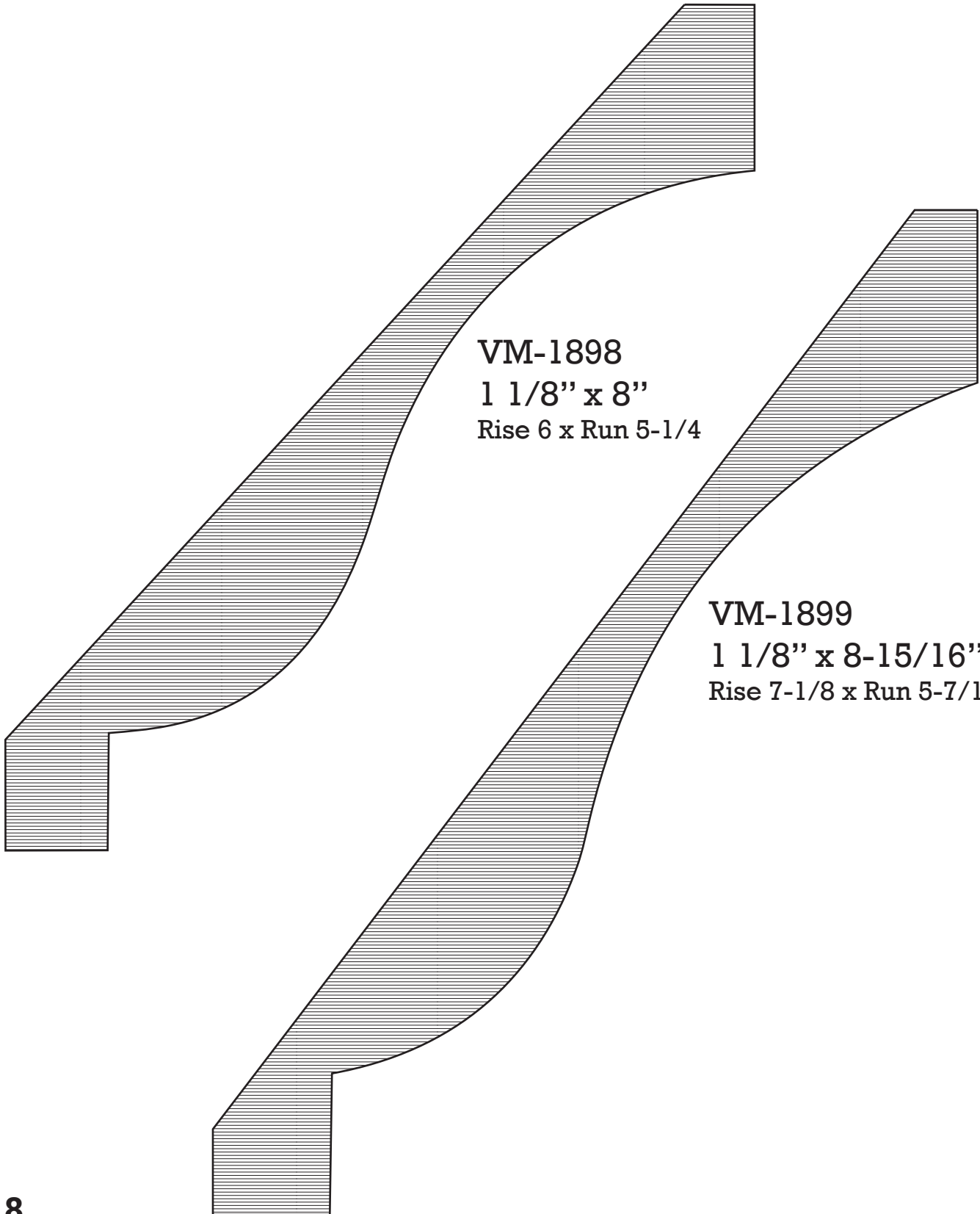

VM-1898  
1 1/8" x 8"  
Rise 6 x Run 5-1/4

VM-1899  
1 1/8" x 8-15/16"  
Rise 7-1/8 x Run 5-7/16



# Crown

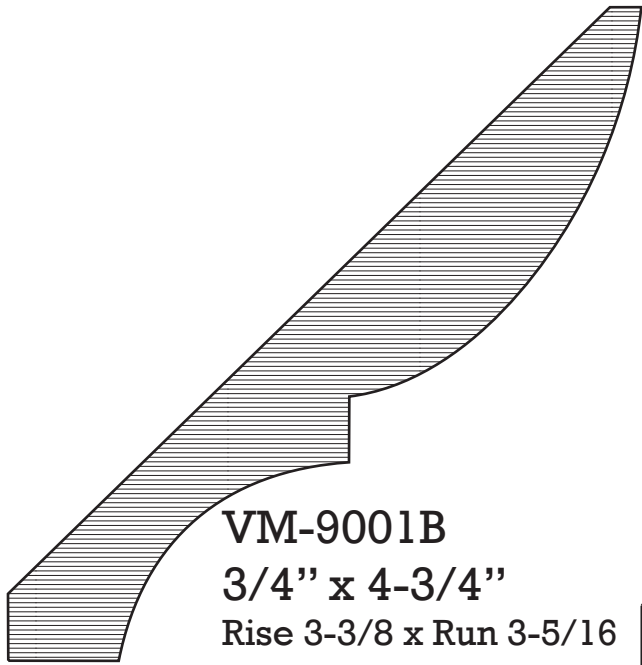

**VM-9001B**  
**3/4" x 4-3/4"**  
Rise 3-3/8 x Run 3-5/16

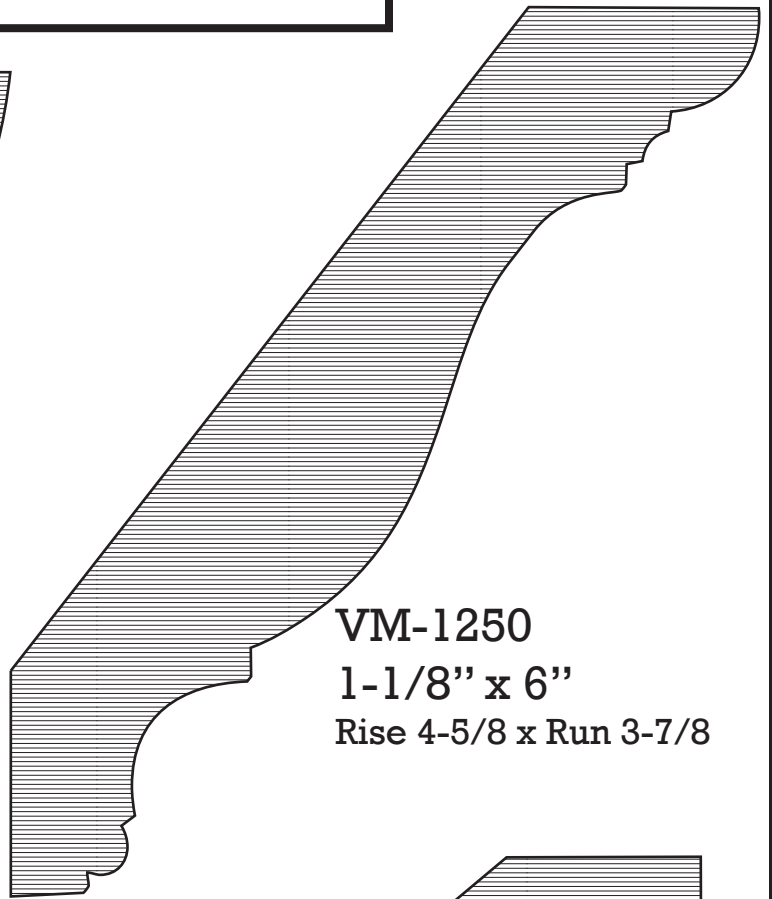

**VM-1250**  
**1-1/8" x 6"**  
Rise 4-5/8 x Run 3-7/8

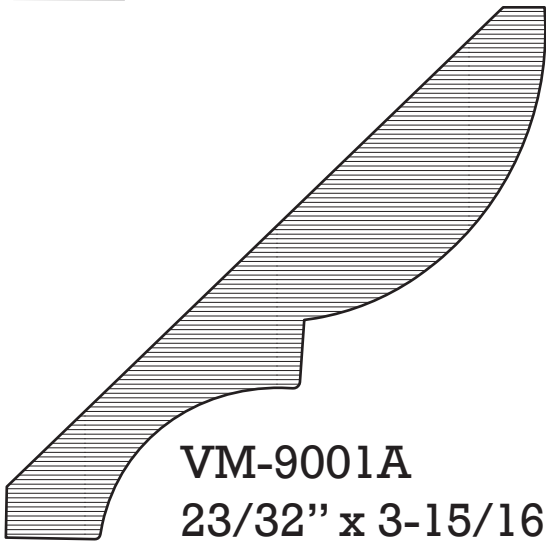

**VM-9001A**  
**23/32" x 3-15/16"**  
Rise 2-5/8 x Run 2-1/2

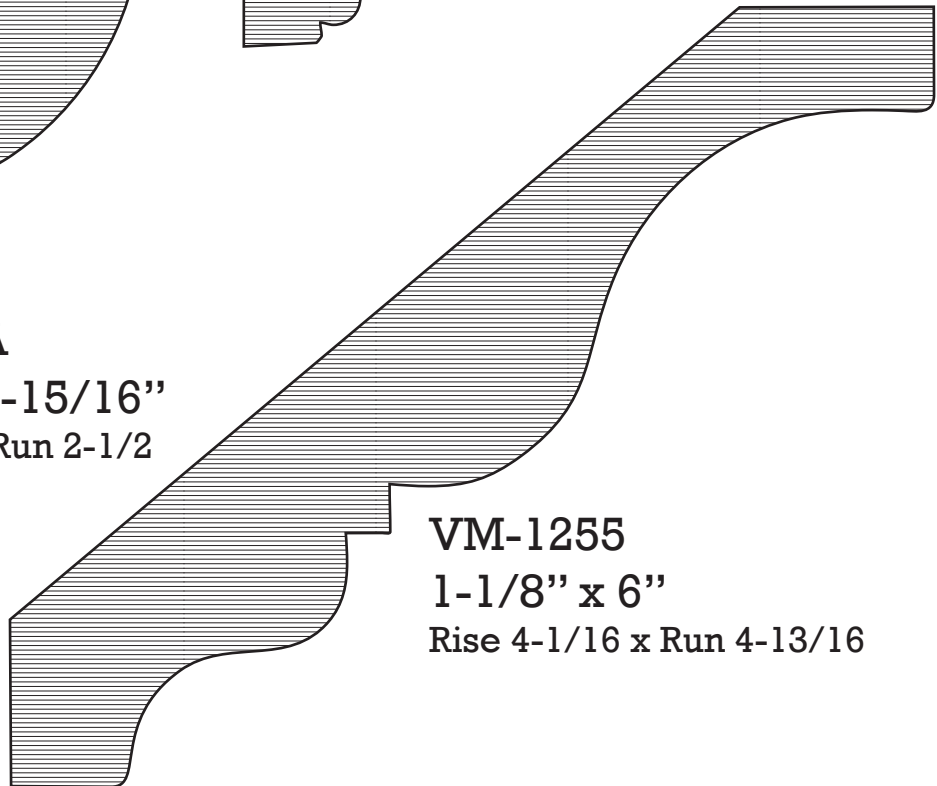

**VM-1255**  
**1-1/8" x 6"**  
Rise 4-1/16 x Run 4-13/16

# Crown

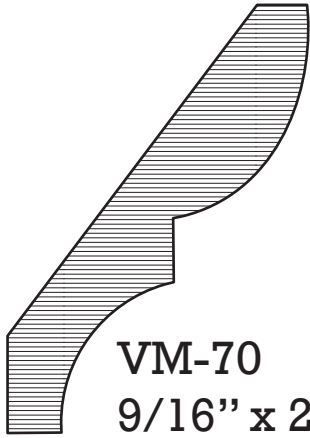

**VM-70**  
9/16" x 2-3/4"  
Rise 2-1/8 x Run 1-5/8



**VM-74**  
9/16" x 1-3/4"  
Rise 1-3/8 x Run 1-1/8



**VM-61**  
9/16" x 1-5/8"  
Rise 1-1/4 x Run 1-1/16

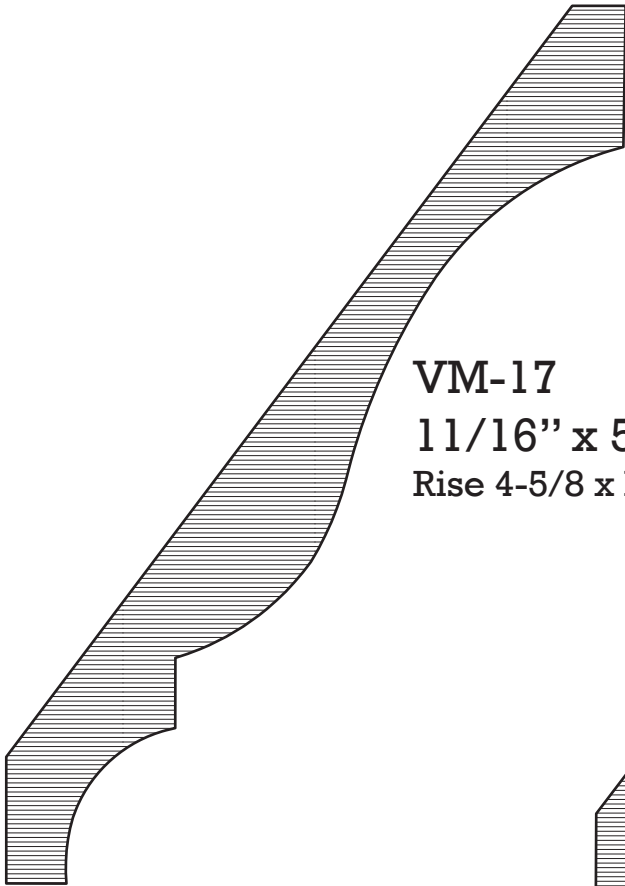

**VM-17**  
11/16" x 5-5/8"  
Rise 4-5/8 x Run 3-1/4

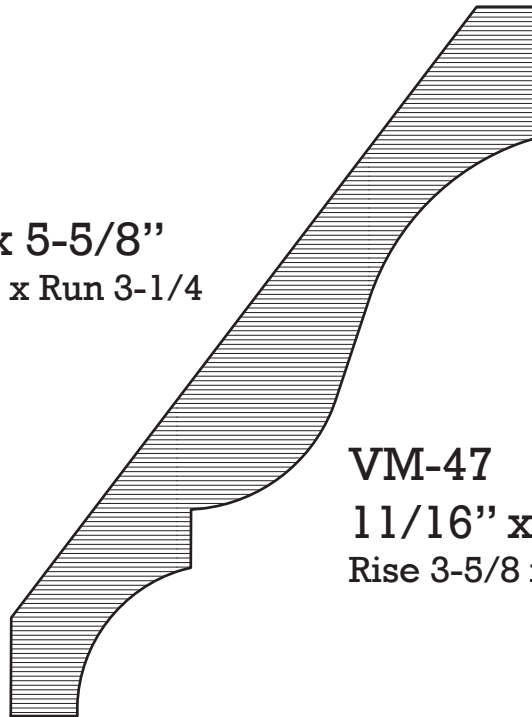

**VM-47**  
11/16" x 4-5/8"  
Rise 3-5/8 x Run 2-7/8

# Crown

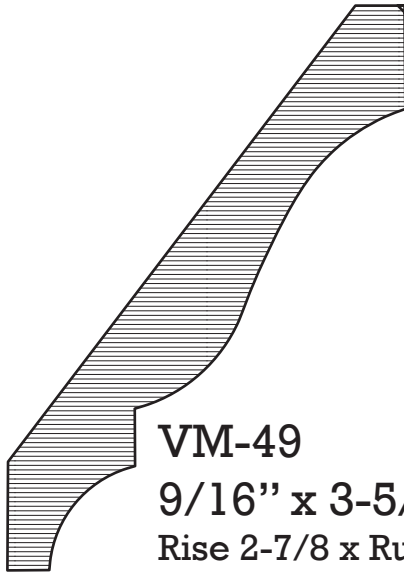

VM-49  
9/16" x 3-5/8"  
Rise 2-7/8 x Run 2-1/16



VM-60  
9/16" x 1-3/4"  
Rise 1-3/8 x Run 1-1/16

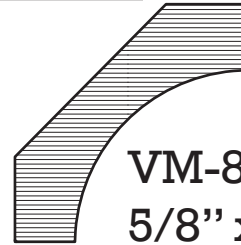

VM-85  
5/8" x 1-3/4"  
Rise 1-1/4 x Run 1-1/4

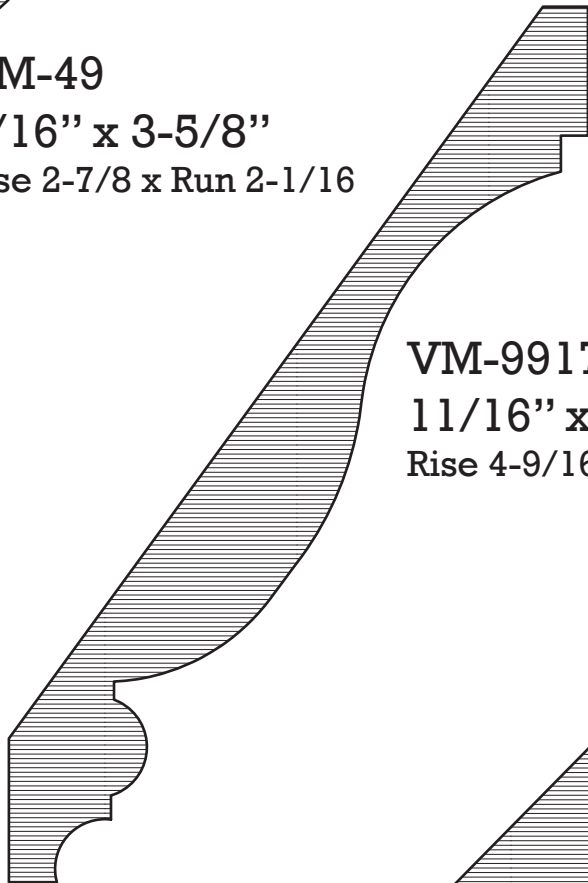

VM-9917  
11/16" x 5-1/2"  
Rise 4-9/16 x Run 3-1/8

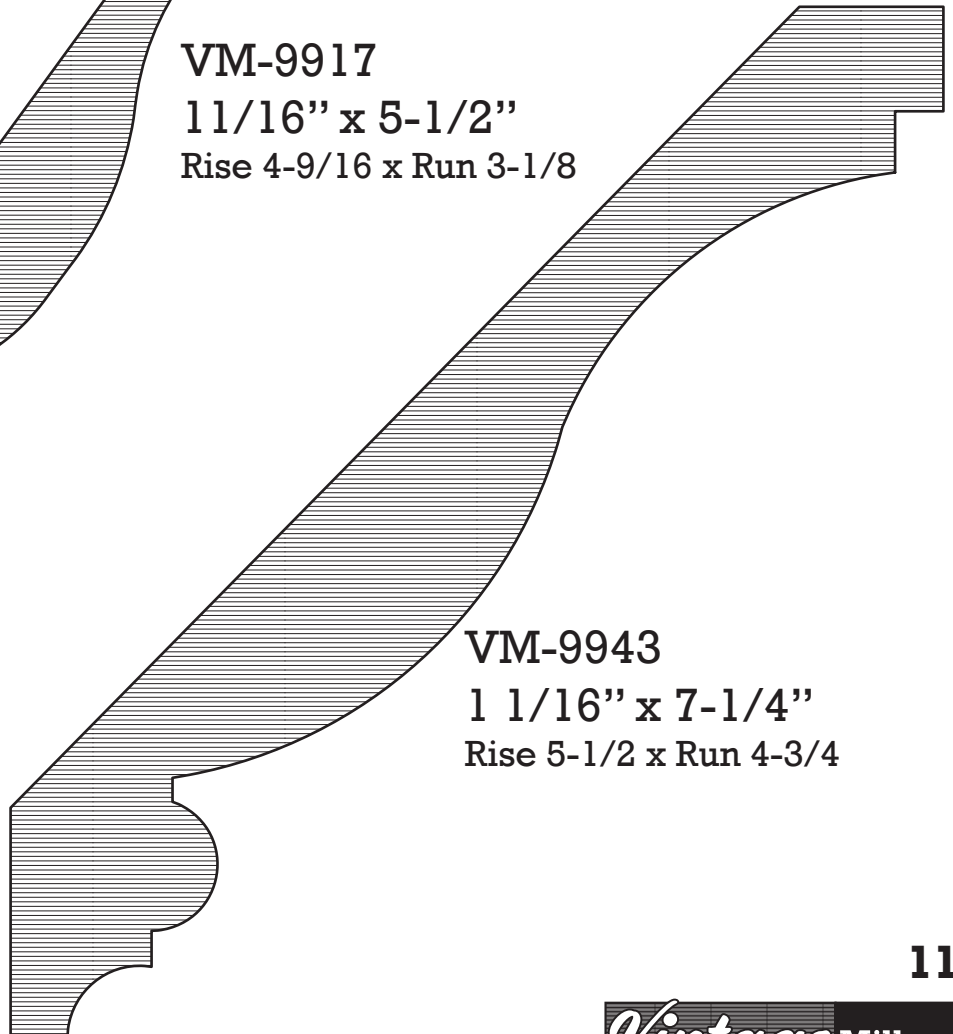

VM-9943  
1 1/16" x 7-1/4"  
Rise 5-1/2 x Run 4-3/4

# Cove Crown

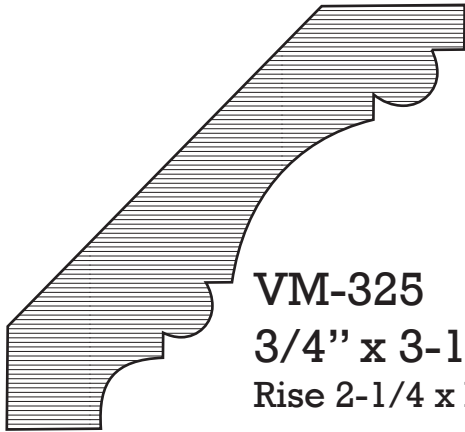

**VM-325**  
**3/4" x 3-1/4"**  
Rise 2-1/4 x Run 2-3/8

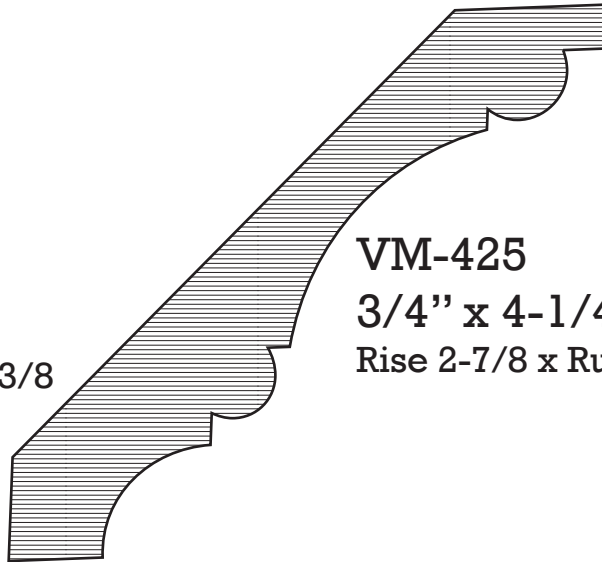

**VM-425**  
**3/4" x 4-1/4"**  
Rise 2-7/8 x Run 3-1/8

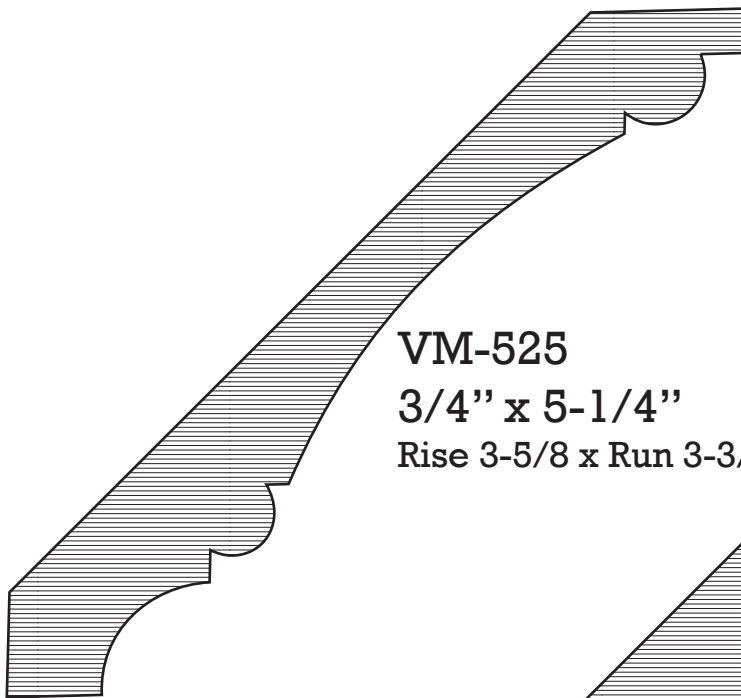

**VM-525**  
**3/4" x 5-1/4"**  
Rise 3-5/8 x Run 3-3/16

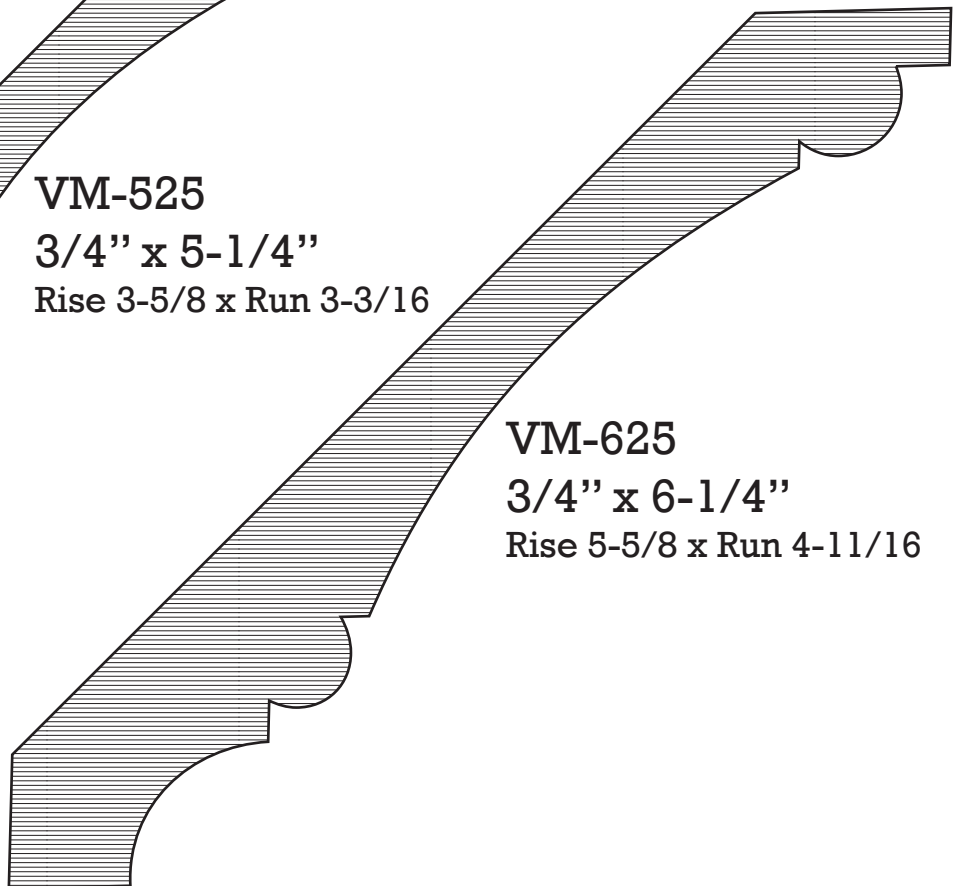

**VM-625**  
**3/4" x 6-1/4"**  
Rise 5-5/8 x Run 4-11/16

# Cove Crown

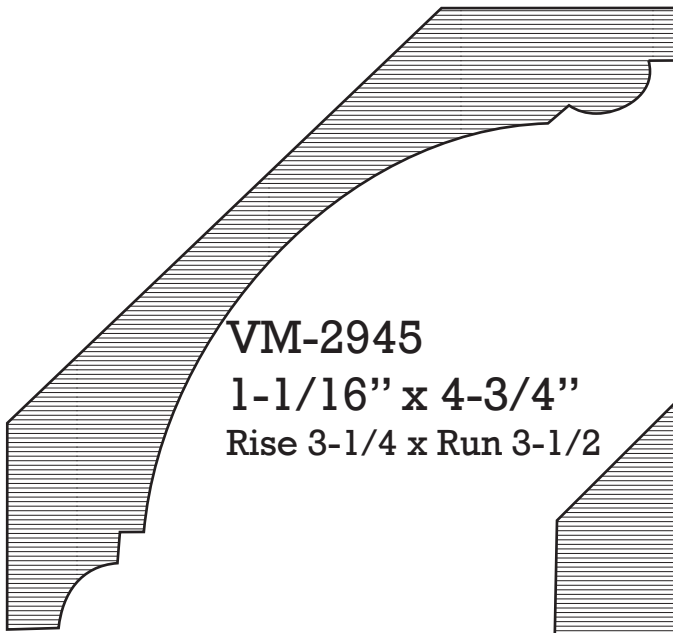

VM-2945  
1-1/16" x 4-3/4"  
Rise 3-1/4 x Run 3-1/2

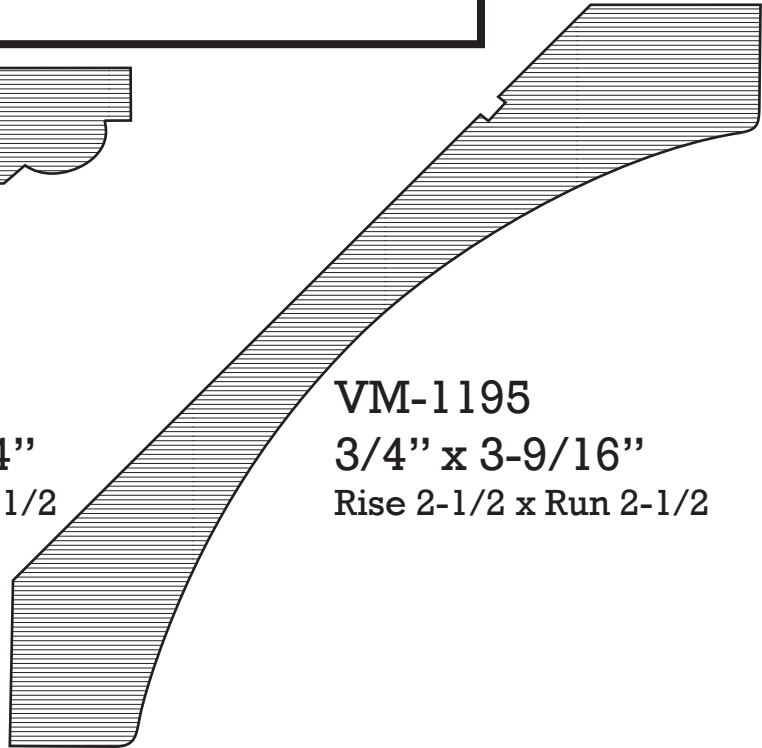

VM-1195  
3/4" x 3-9/16"  
Rise 2-1/2 x Run 2-1/2

VM-9304  
8" x 6-3/4"  
Rise 4-3/4 x Run 4-13/16

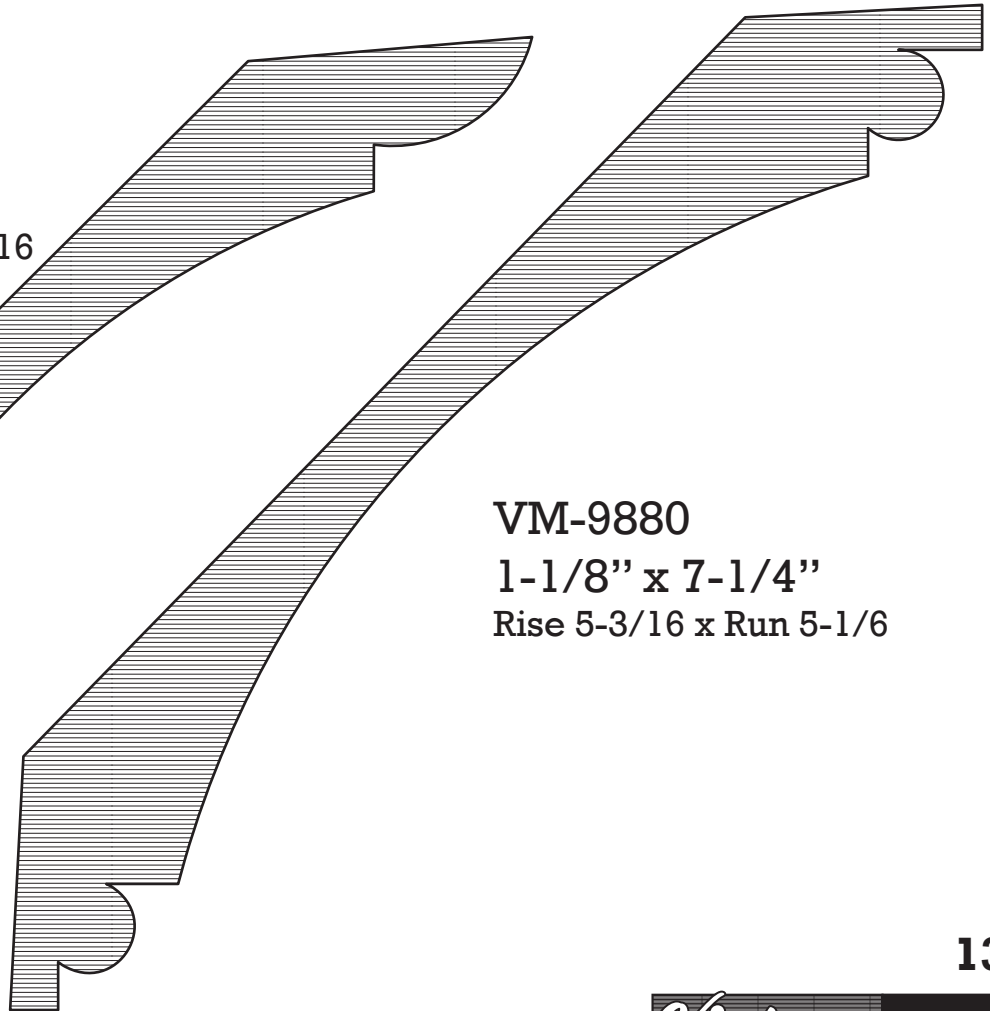
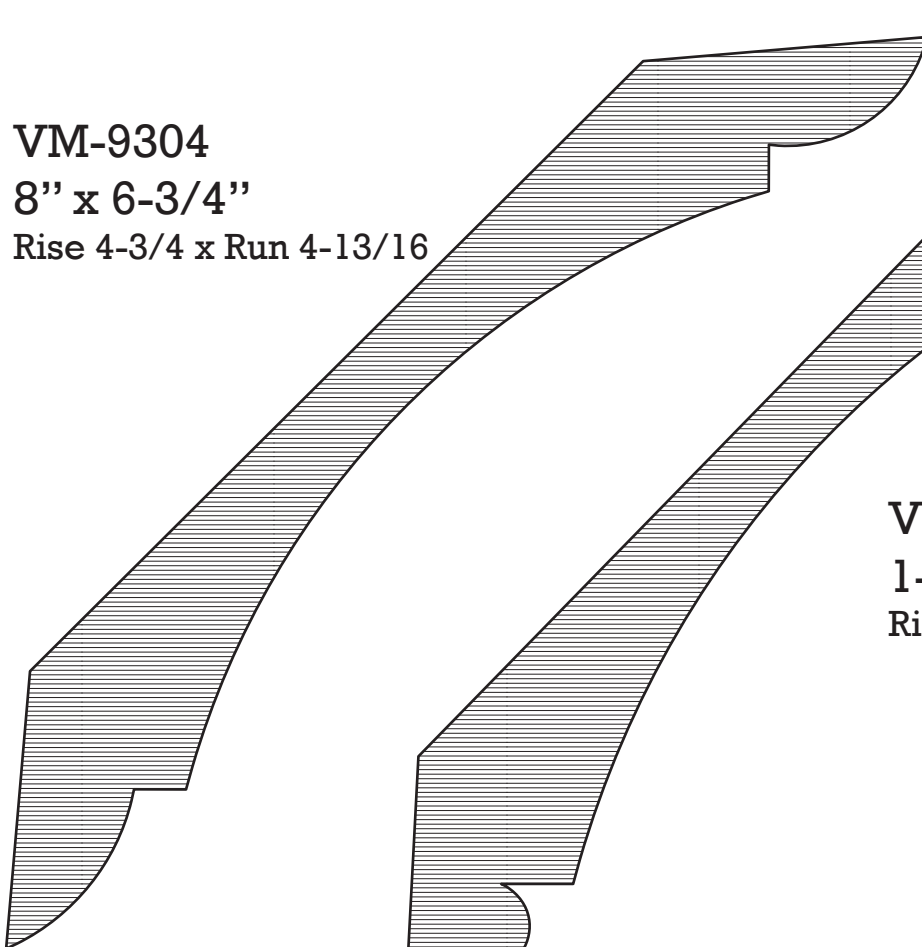

VM-9880  
1-1/8" x 7-1/4"  
Rise 5-3/16 x Run 5-1/6

# Dentil Crown

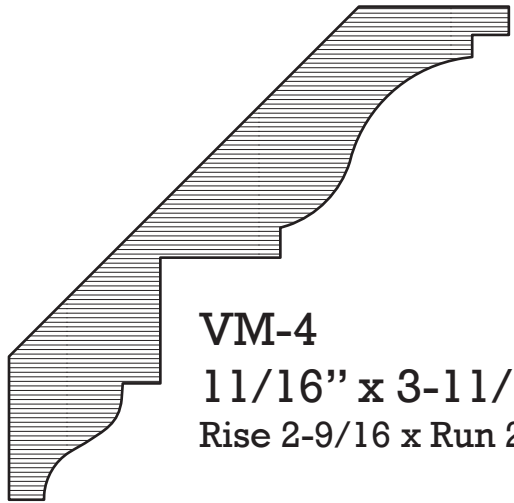

VM-4  
1 1/16" x 3-11/16"  
Rise 2-9/16 x Run 2-11/16

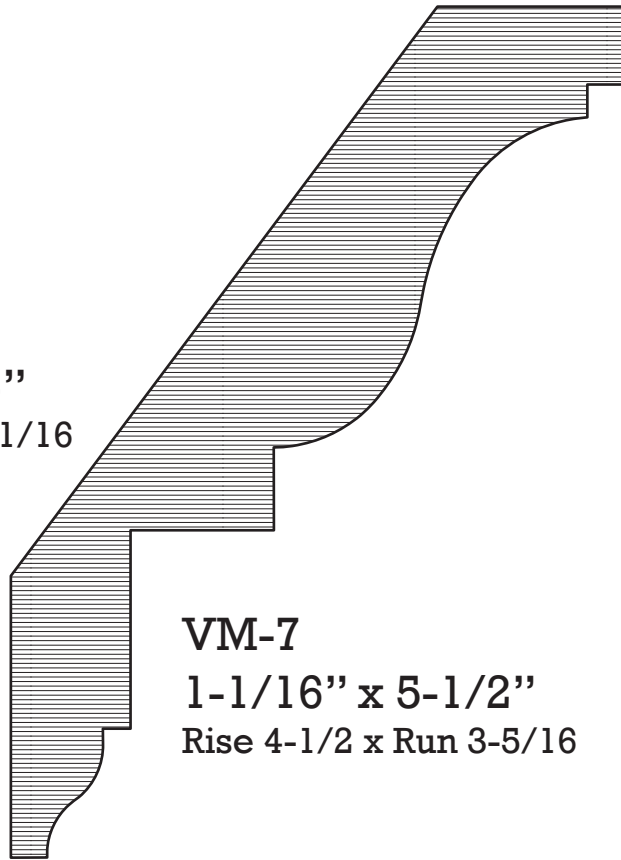

VM-7  
1-1/16" x 5-1/2"  
Rise 4-1/2 x Run 3-5/16

(Fits in VM-4)

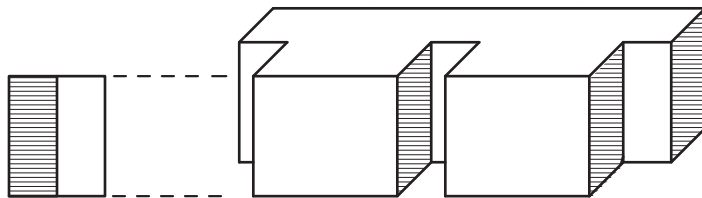

VM-18  
1/2" x 5/8"

(Fits in VM-7)

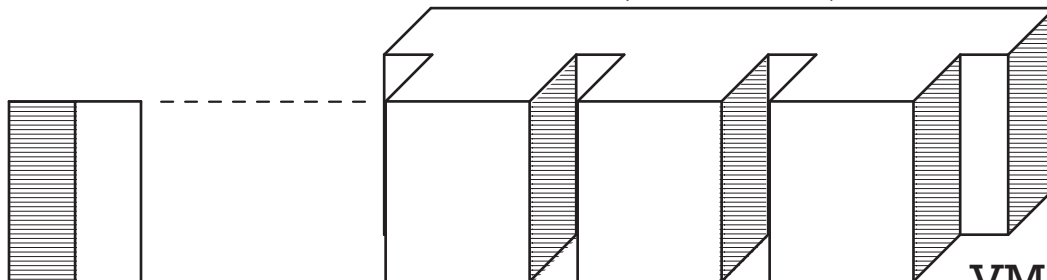

VM-707  
1 1/16" x 15/16"

# Dentil Crown

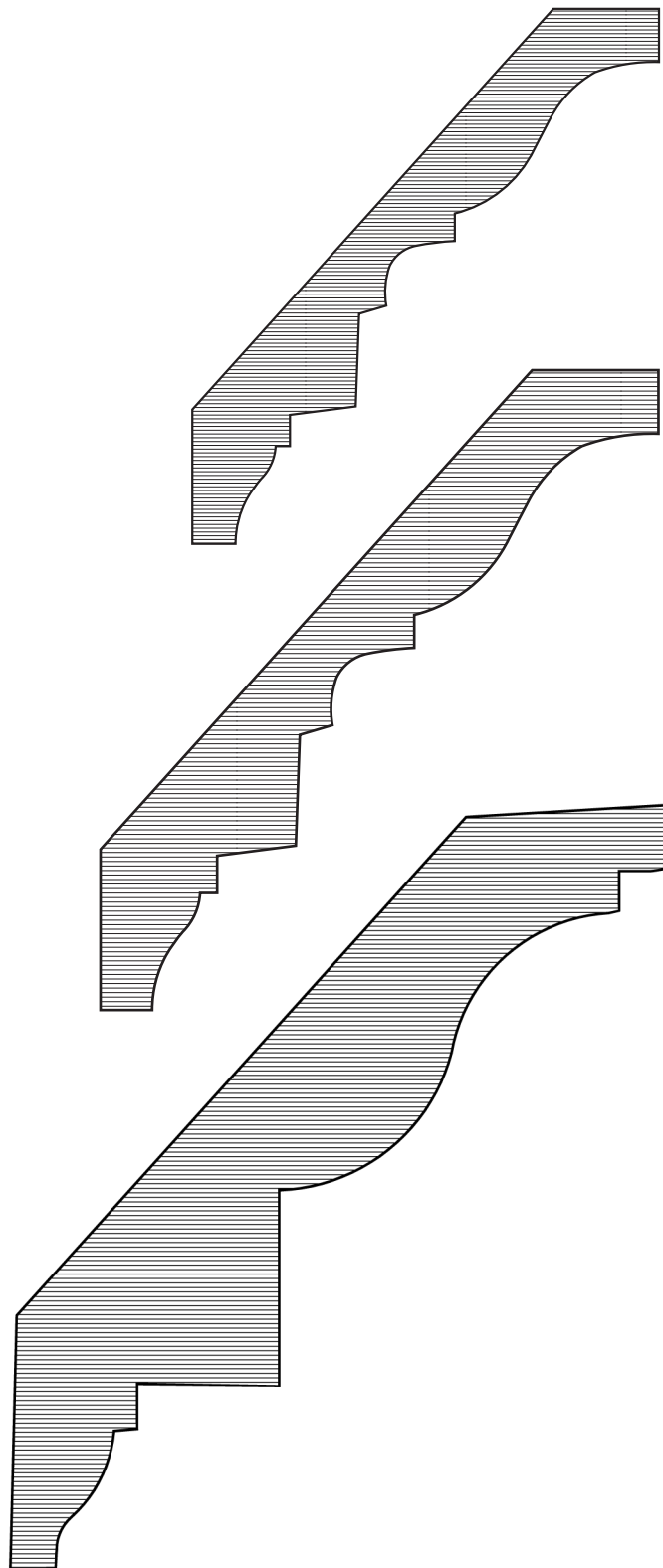

VM-358

1 1/16" x 3-5/8"

Rise 2-13/16 x Run 2-1/4

VM-161

1 1/16" x 4-1/4"

Rise 3-1/4 x Run 2-5/8

VM-514

1-3/16" x 5-5/16"

Rise 4-3/16 x Run 3-3/8

# Dentil Mould

In addition to dentil inserts and speed dentil crown, we have the ability to mill the various dentil designs seen below. Contact us for more finished product dimensional information.

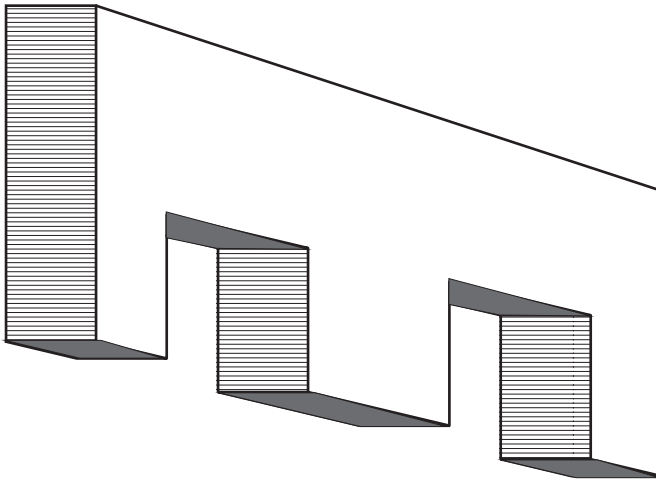

## **Full Cut Dentil**

1/4" x 1"  
1/2" x 1-1/2"  
1/2" x 1-3/4"  
1/2" x 2"  
1" x 4"  
1-1/4" x 4"  
2" x 4"  
2" x 6"

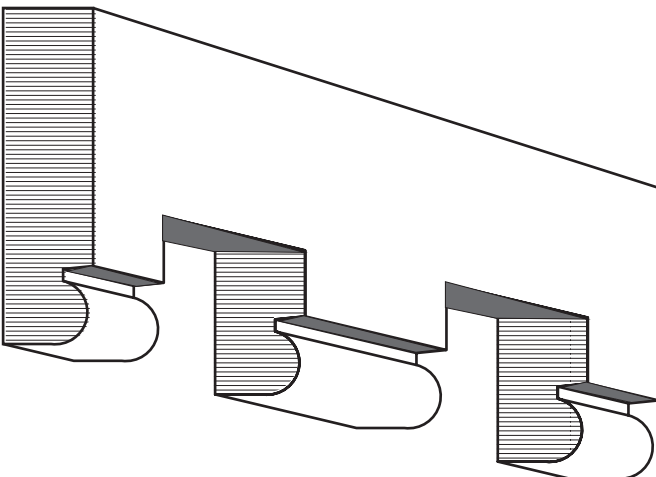

## **Beaded Dentil**

1/2" x 1-1/2"  
1/2" x 1-3/4"



# Base Board

VM-627  
5/8" x 5"

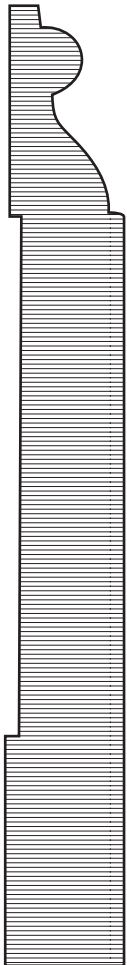

VM-2399  
5/8" x 5-1/2"

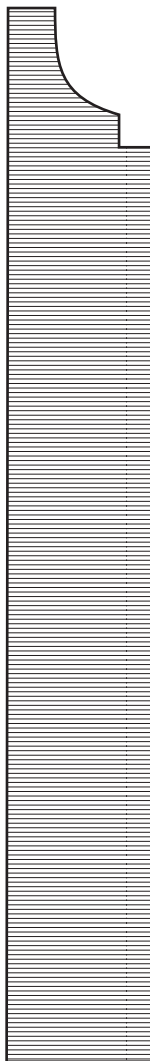

VM-629  
1" x 6"



VM-642  
3/4" x 7-1/2"

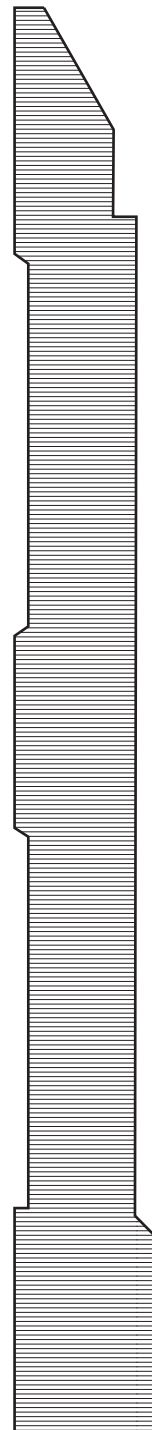

VM-714  
1/2" x 7-1/4"

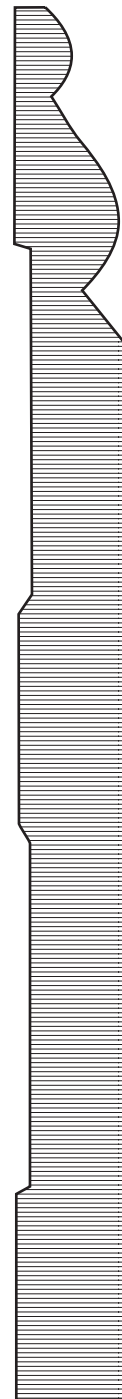

# Base Board

VM-3378  
3/4" x 7-1/2"

VM-3376  
3/4" x 6-1/4"

VM-3374  
3/4" x 5-1/4"

VM-3372  
3/4" x 4-1/4"

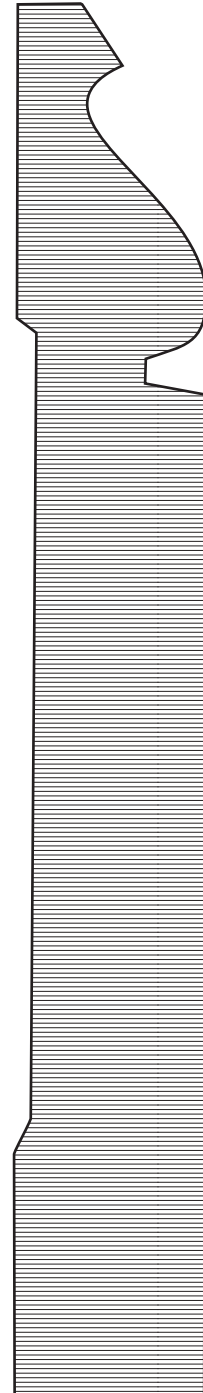
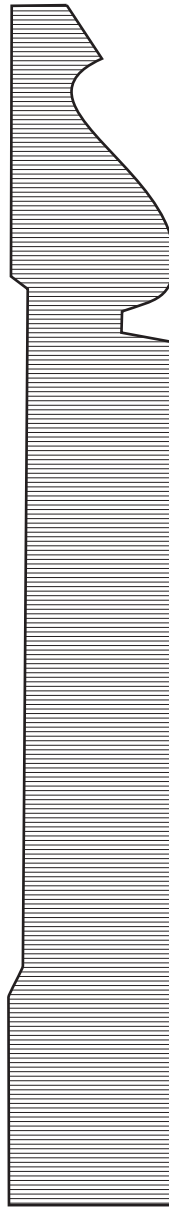
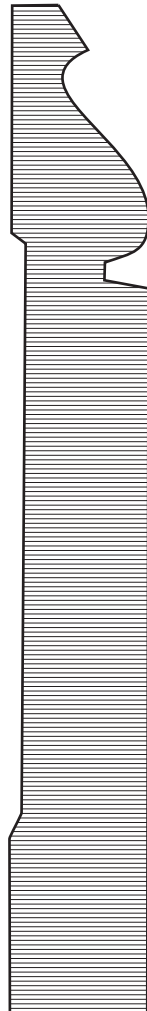

# Base Board

VM-3482  
3/4" x 7-1/4"

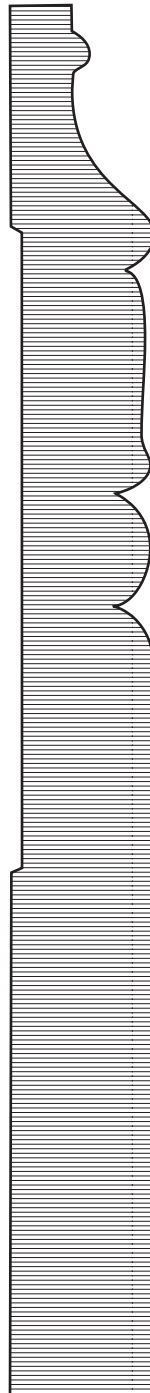

VM-3472  
3/4" x 6-1/4"

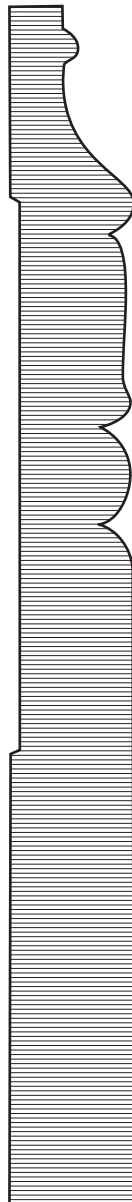

VM-3462  
3/4" x 5-1/4"

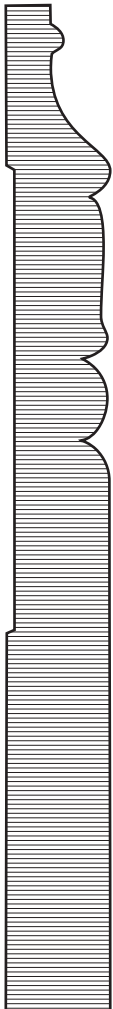

VM-3678  
3/4" x 5-1/4"

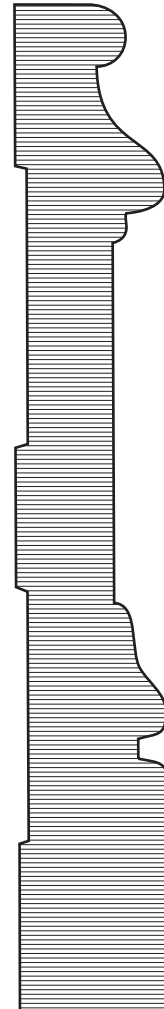

# Base Board

VM-618  
9/16" x 5-1/4"

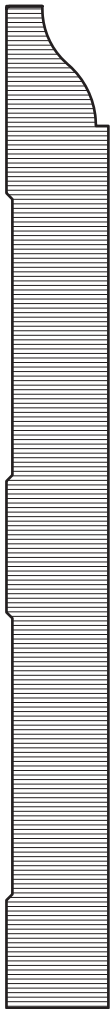

VM-620  
9/16" x 4-1/4"

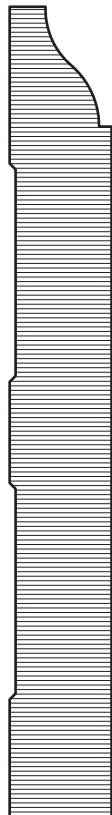

VM-623  
9/16" x 3-1/4"



VM-713  
9/16" x 3-1/4"



# Casing

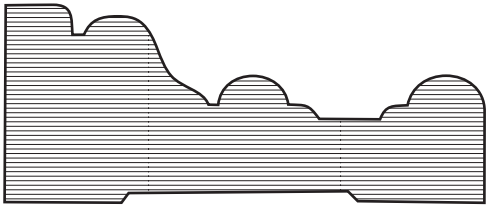

VM-2200  
1-1/16" x 2-1/2"

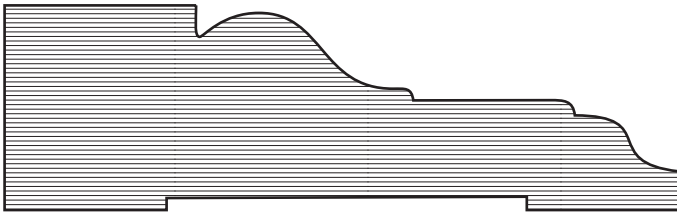

VM-2201  
1" x 3-1/2"

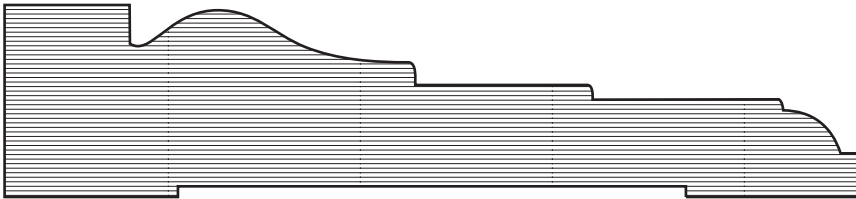

VM-2202  
1" x 4-1/2"

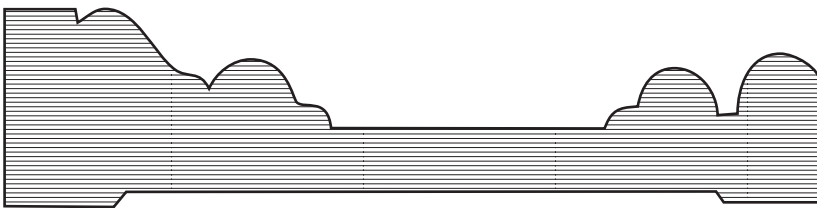

VM-3300  
1-1/16" x 4-1/2"

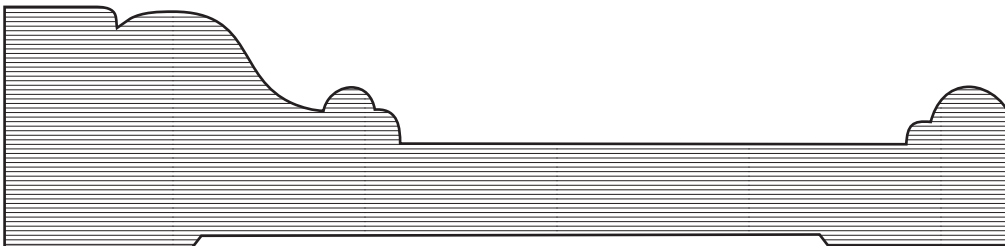

VM-3320  
1-1/4" x 5-1/4"

# Casing

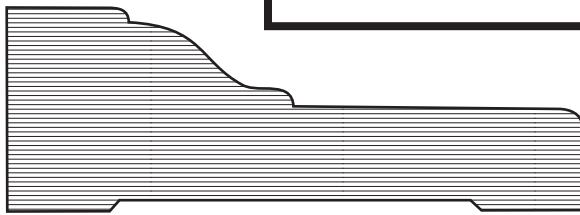

VM-4710  
1-1/16" x 3"

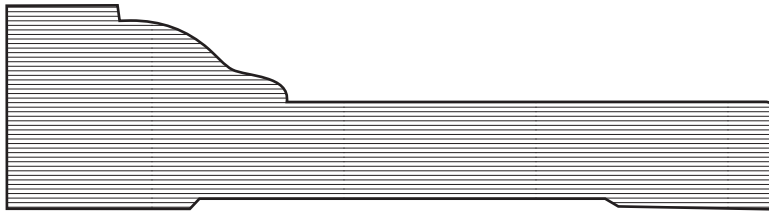

VM-4713  
1-1/16" x 4"

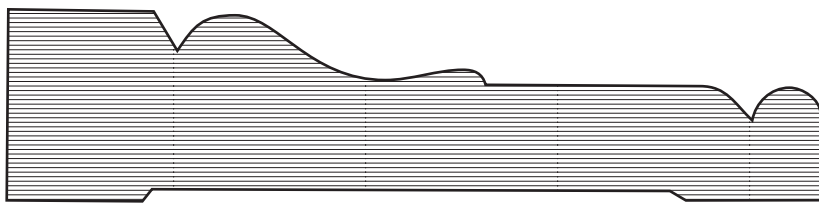

VM-4725  
1" x 4-1/4"

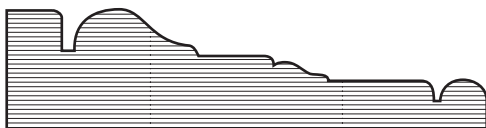

VM-4748  
5/8" x 2-1/2"

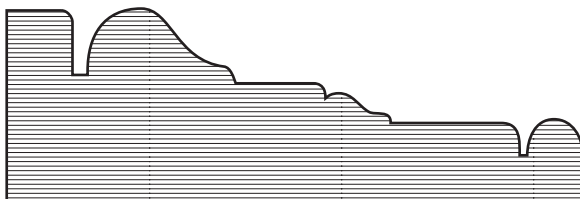

VM-4749  
1" x 3"

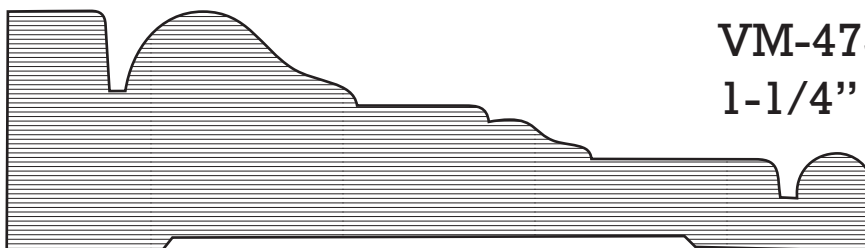

VM-4750  
1-1/4" x 4-1/2"

# Casing

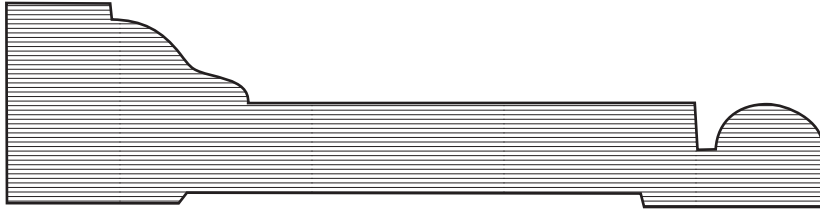

VM-4801  
1-1/16" x 4-1/4"

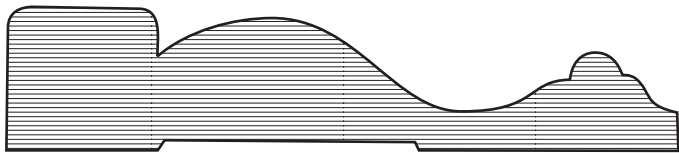

VM-6876  
3/4" x 3-1/2"

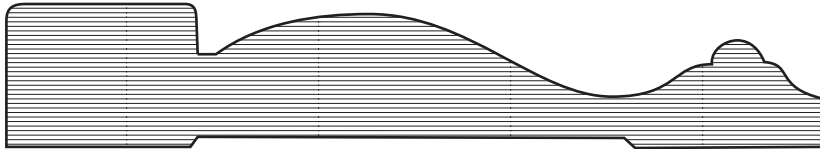

VM-6878  
3/4" x 4-1/4"

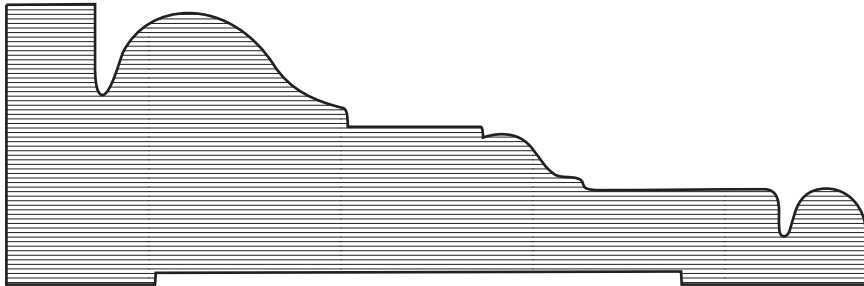

VM-9821  
1-1/2" x 4-1/2"

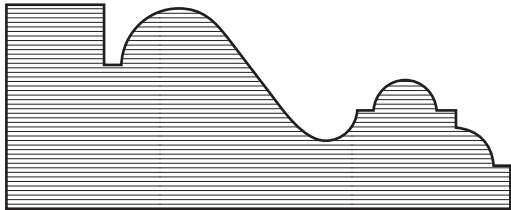

VM-9939  
1-1/16" x 2-5/8"

# Casing

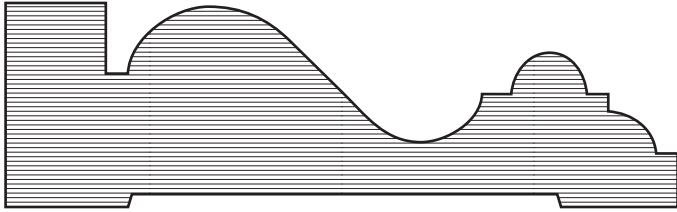

VM-9947  
1-1/16" x 3-1/2"

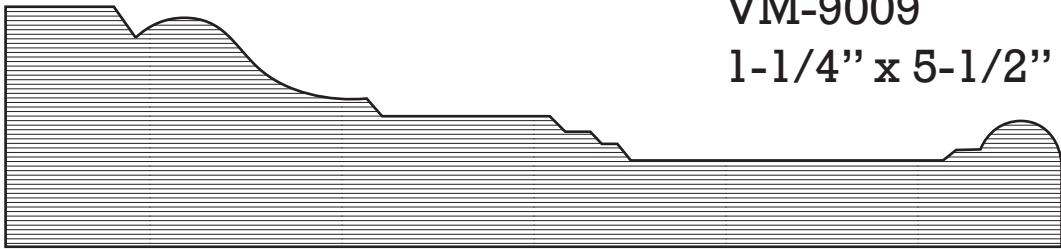

VM-9009  
1-1/4" x 5-1/2"



VM-482  
1-1/4" x 4-1/2"

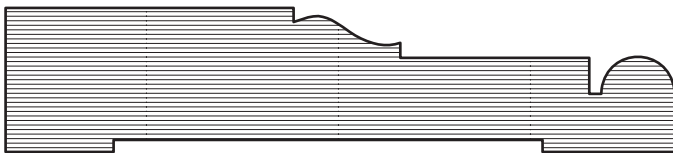

VM-9823A  
3/4" x 3-1/2"

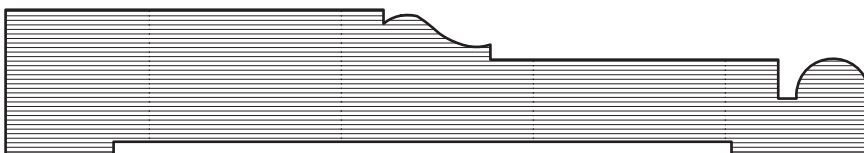

VM-9823B  
3/4" x 4-1/2"



# Casing

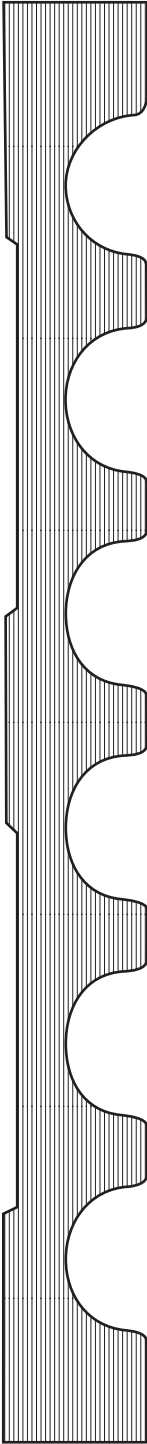

VM-5488  
3/4" x 7-1/2"

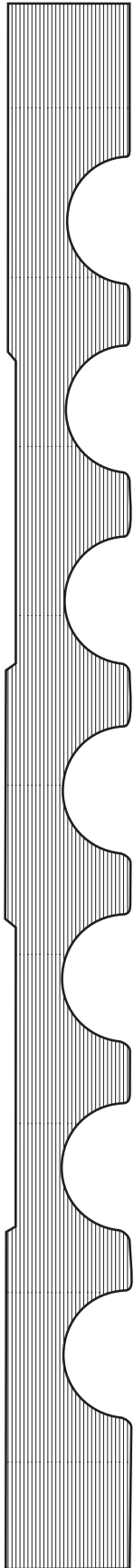

VM-5498  
3/4" x 9-1/2"

# Casing

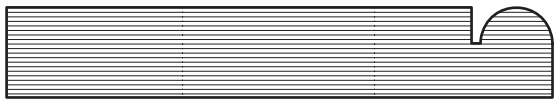

VM-8801  
1/2" x 2-7/8"

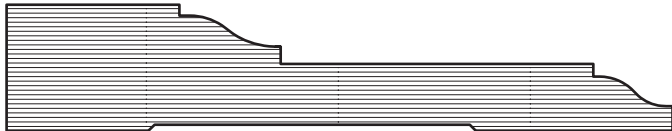

VM-8846  
11/16" x 3-1/2"

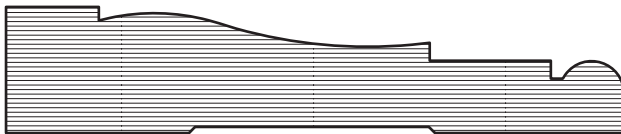

VM-445  
11/16" x 3-1/4"

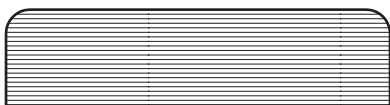

VM-8905  
1/2" x 2"

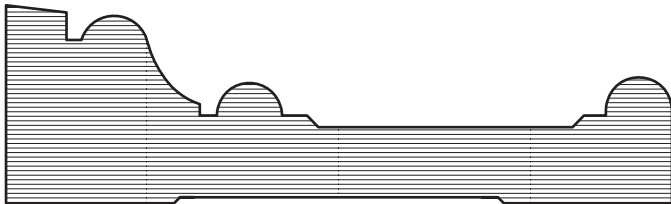

VM-3  
1-1/16" x 3-1/2"

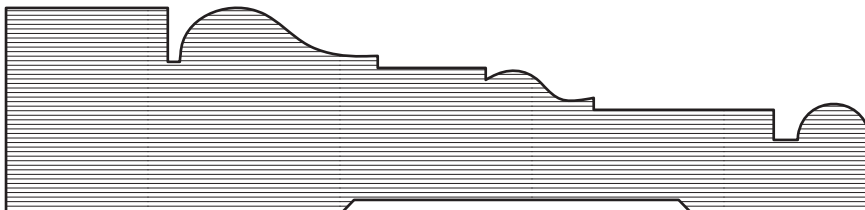

VM-9901  
1-1/4" x 4-1/2"

# Casing

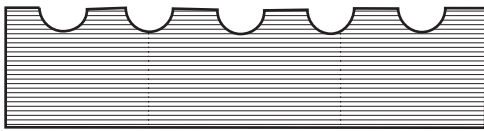

VM-5663  
5/8" x 2-1/2"

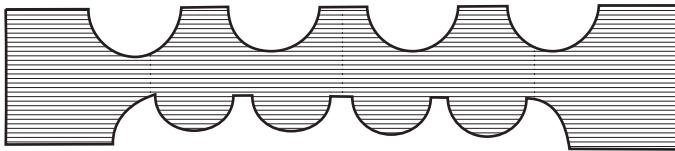

VM-5965  
3/4" x 3-1/2"

VM-5478  
3/4" x 5-1/2"

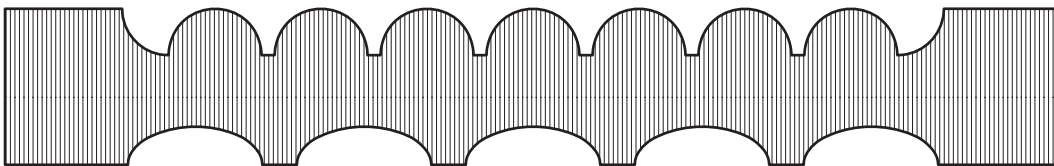
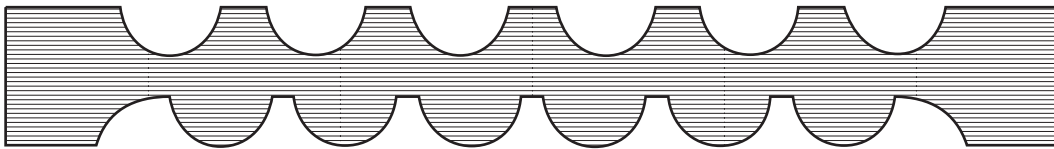

VM-9002  
13/16" x 5-1/2"

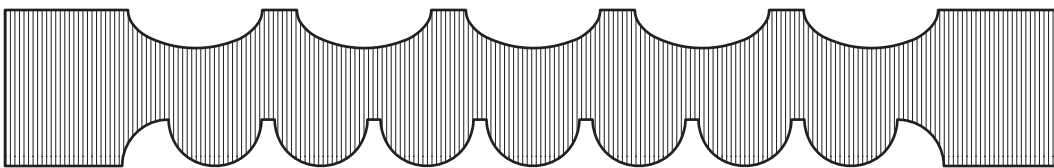

VM-9003  
13/16" x 7-1/4"

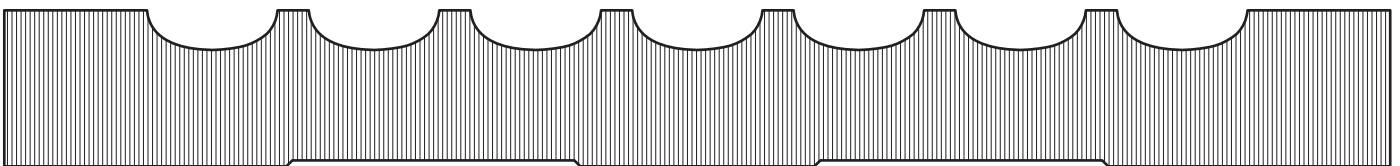

# Casing

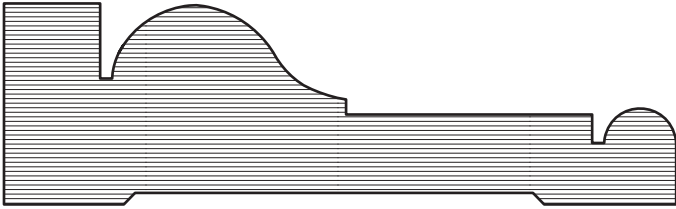

VM-9825  
1-1/16" x 3-1/2"

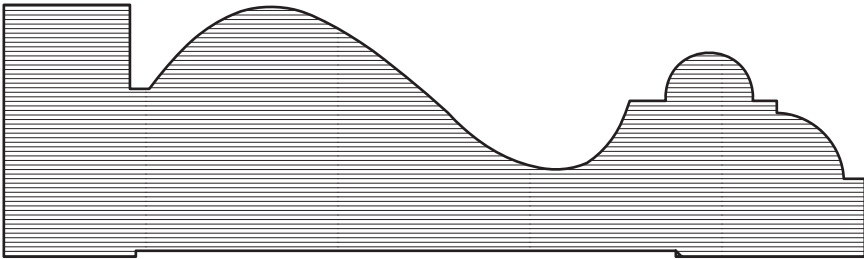

VM-9827  
1-1/4" x 4-1/2"

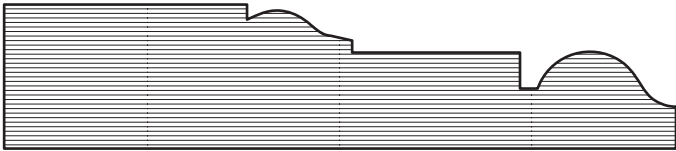

VM-9837A  
3/4" x 3-1/2"

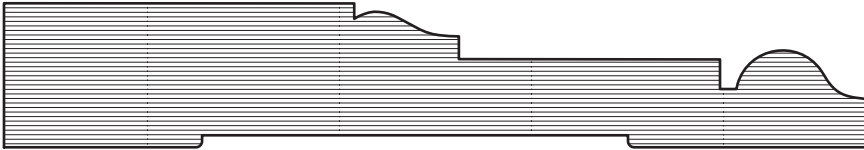

VM-9837B  
3/4" x 4-1/2"

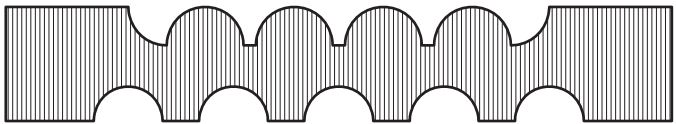

VM-6  
5/8" x 3-1/2"

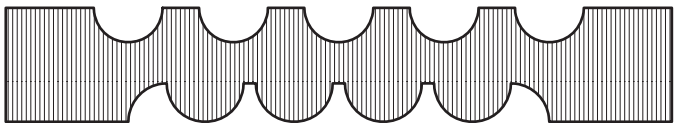

# Plinth Block

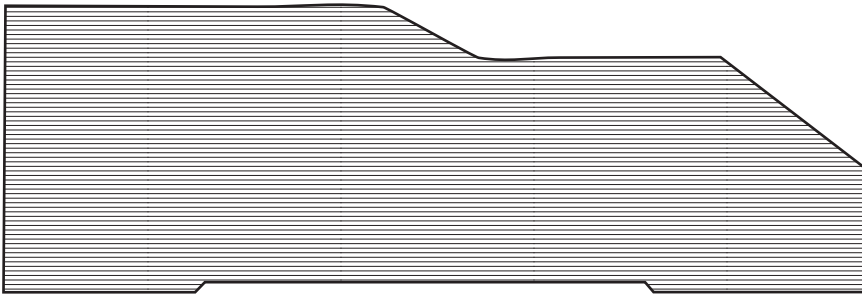

VM-197  
1-1/2" x 4-1/2"

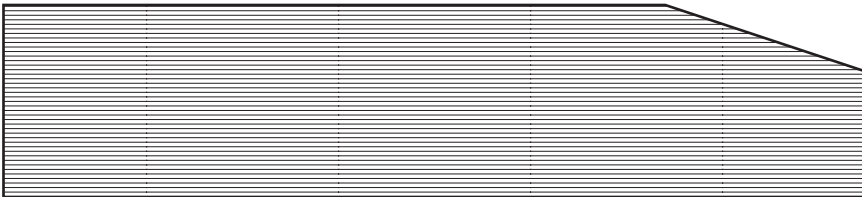

VM-2400  
1" x 4-1/2"



VM-2700  
1-3/8" x 5-3/4"



VM-3325  
1-3/8" x 5-1/2"

# Plinth Block

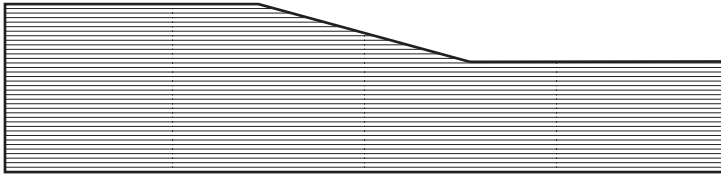

VM-3700  
7/8" x 3-3/4"



VM-6800  
1" x 4-1/2"

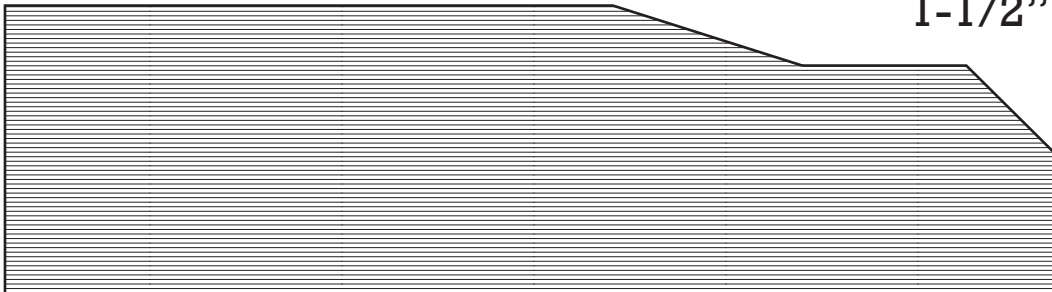

VM-9800  
1-1/2" x 5-1/2"

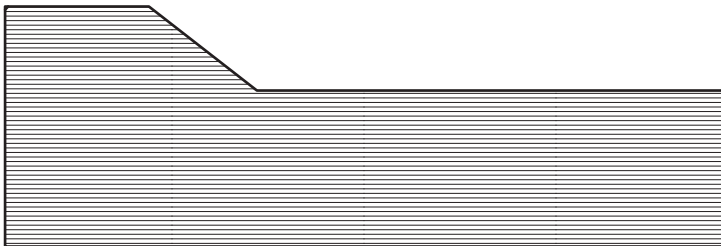

VM-27  
1-1/4" x 3-3/4"

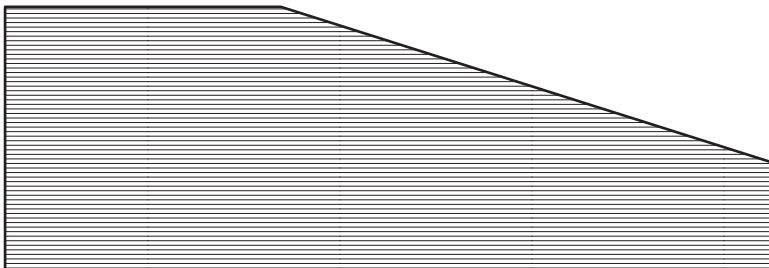

VM-8810  
1-3/8" x 4"

# Plinth Block

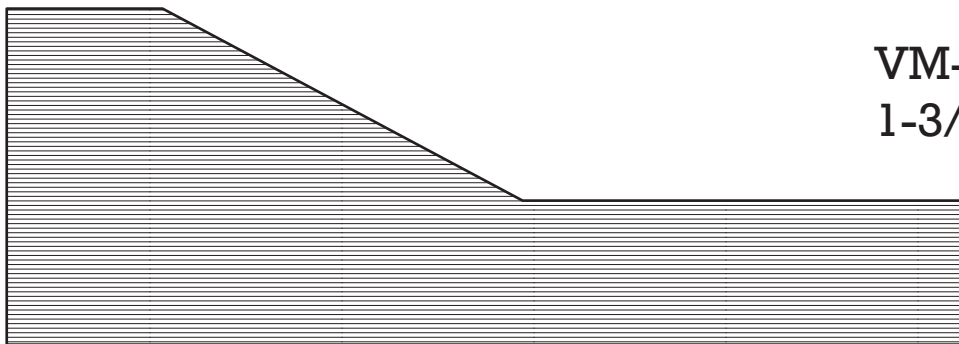

VM-8811  
1-3/4" x 5"

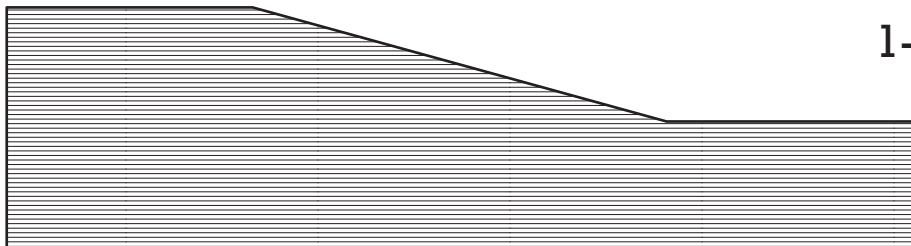

VM-9929  
1-1/4" x 4-3/4"

# Back Band

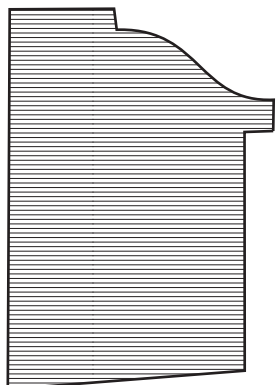

VM-282  
1-3/8" x 2"

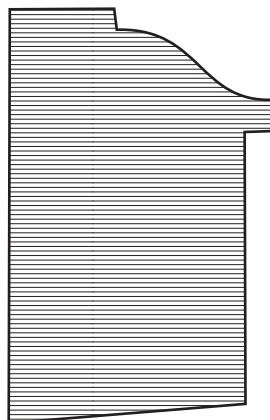

VM-283  
1-3/8" x 2-3/8"

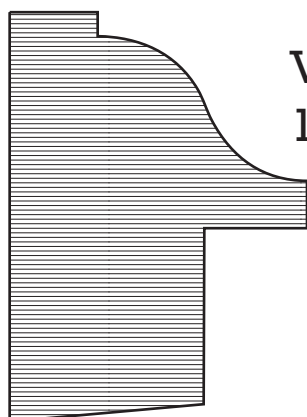

VM-284  
1-9/16" x 2-1/8"

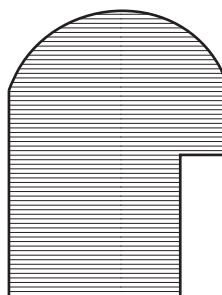

VM-285  
1-1/8" x 1-1/2"

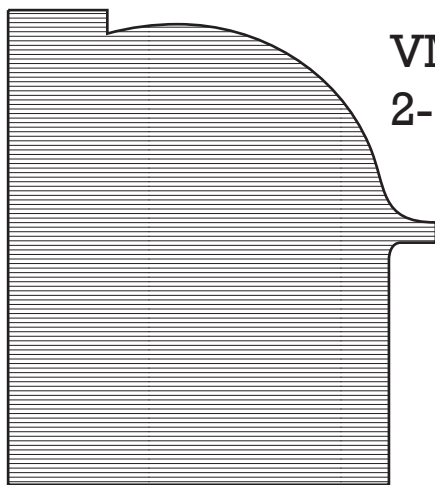

VM-288  
2-1/4" x 2-1/2"

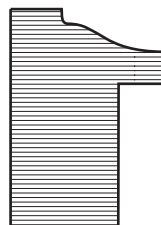

VM-1820  
7/8" x 1-1/8"

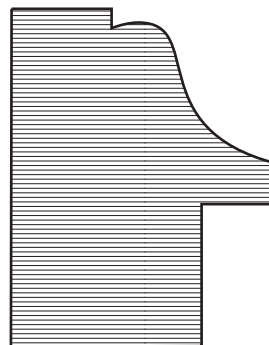

VM-286  
1-3/8" x 1-3/4"



# Back Band

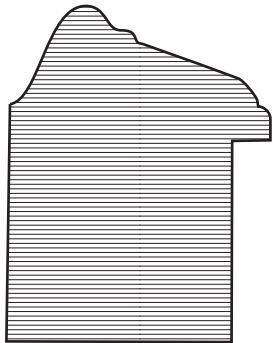

VM-8819  
1-3/8" x 1-3/4"

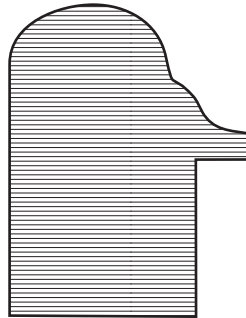

VM-7321  
1-1/4" x 1-5/8"

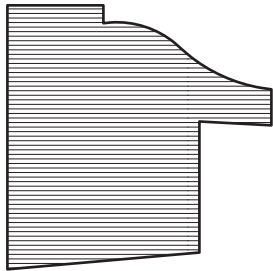

VM-281  
1-3/8" x 1-3/8"

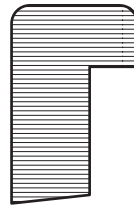

VM-280  
1-1/16" x 11/16"

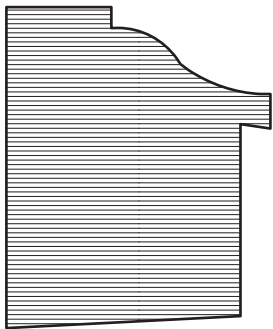

VM-8809  
1-5/8" x 1-3/8"

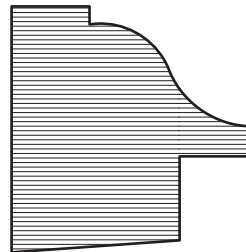

VM-8808  
1-1/4" x 1-1/4"

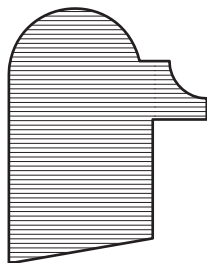

VM-9902  
1-5/16" x 1-1/16"

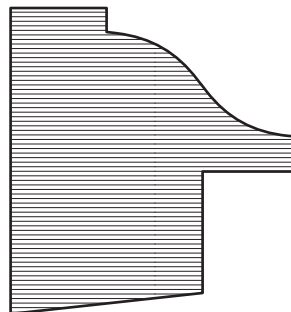

VM-9940  
1-5/8" x 1-1/2"

# Mull Casing

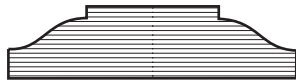

VM-9848  
3/8" x 1-1/2"

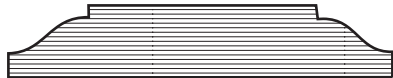

VM-9864  
3/8" x 2"

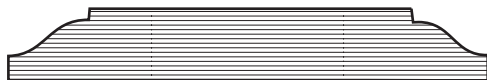

VM-9865  
3/8" x 2-1/2"

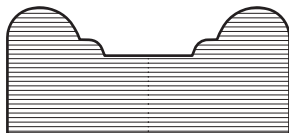

VM-220A  
11/16" x 1-1/2"

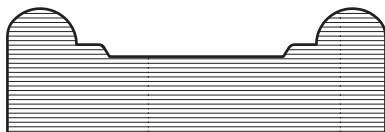

VM-220B  
11/16" x 2"

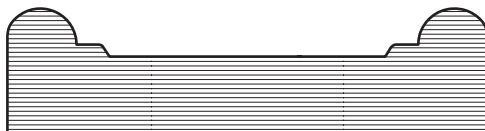

VM-220C  
11/16" x 2-1/2"



VM-220D  
11/16" x 3"

# Pilaster

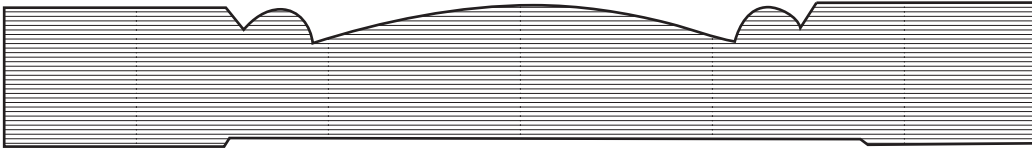

VM-4248  
3/4" x 5-1/2"

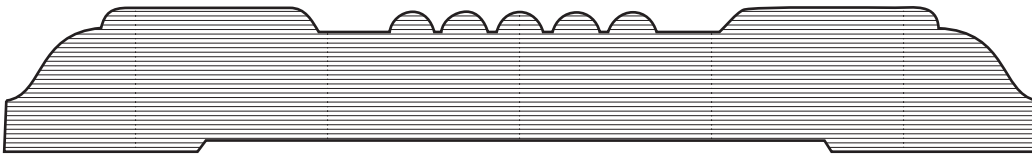

VM-4448  
3/4" x 5-1/2"

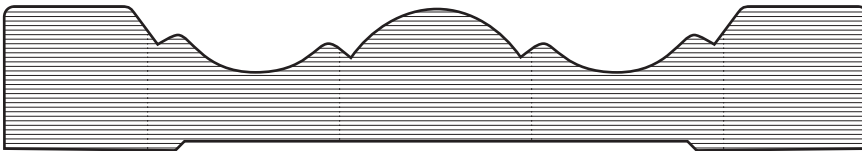

VM-7301  
3/4" x 4-1/2"

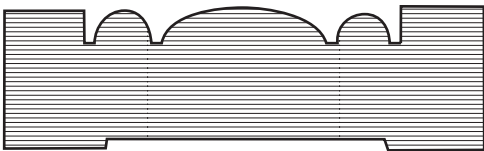

VM-7685  
3/4" x 2-1/2"

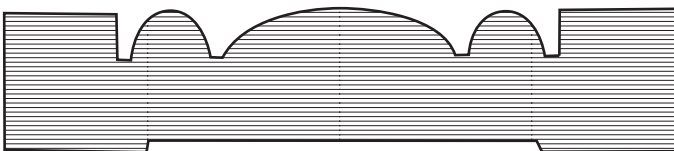

VM-7695  
3/4" x 3-1/2"

# Chair Rail

VM-804  
3/4" x 4-7/8"

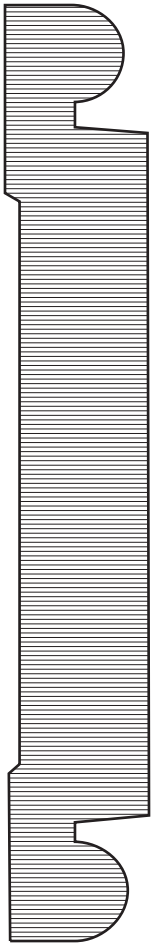

VM-1905  
1-1/16" x 2-3/4"

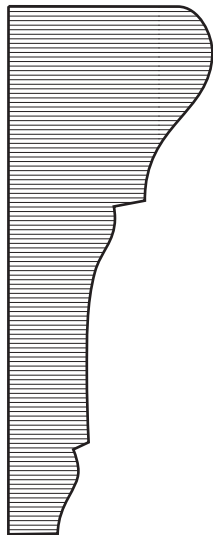

VM-2369  
1/2" x 2-1/4"



VM-2375  
3/4" x 3-1/2"

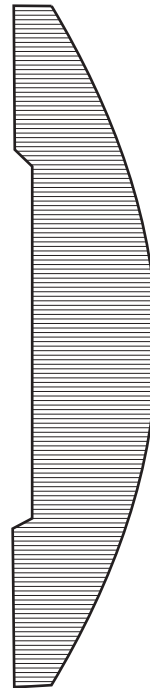

VM-1303  
1-1/4" x 2-7/8"

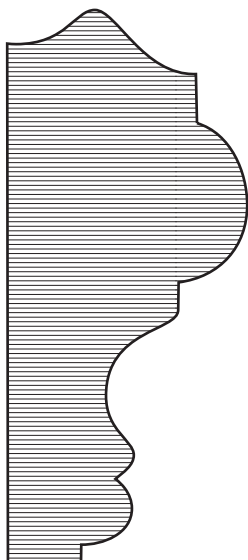

VM-1305  
1-1/2" x 3-1/2"

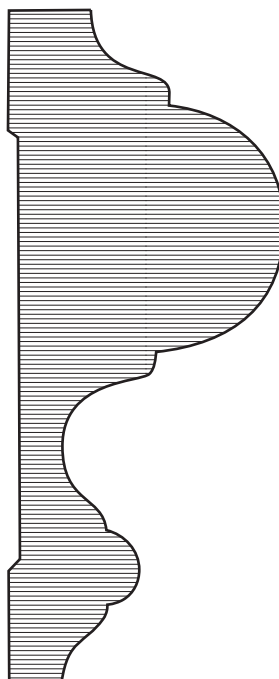

VM-1567  
3/4" x 2-7/8"

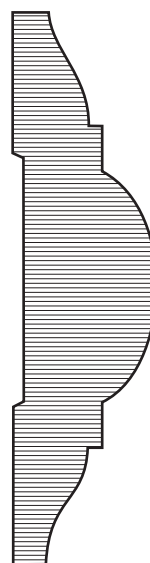

# Chair Rail

VM-2904

1-1/4" x 3-1/4"

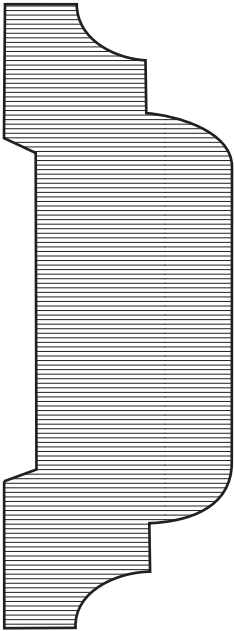

VM-2907

3/4" x 3-1/8"

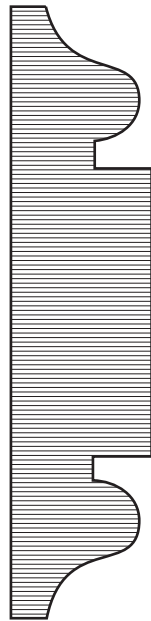

VM-6248

3/4" x 3"

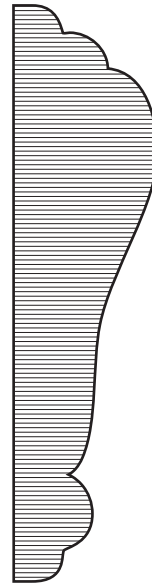

VM-7475

1/2" x 2"



VM-7485

1/2" x 2-3/4"



VM-7791

3/4" x 2-5/8"

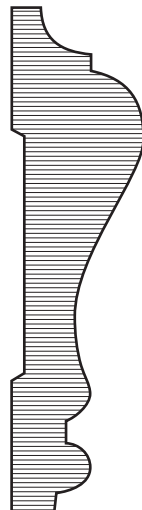

VM-8805

1" x 2-1/2"

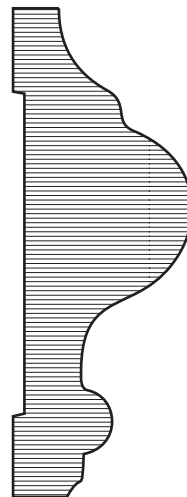

VM-8807

1-1/4" x 2-15/16"

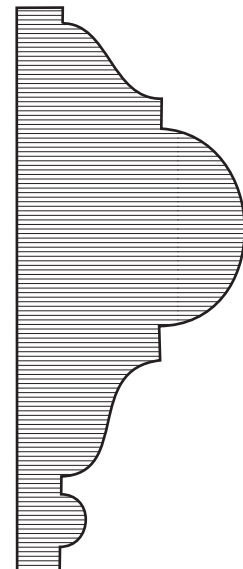

# Chair Rail

VM-8822  
3/4" x 6"

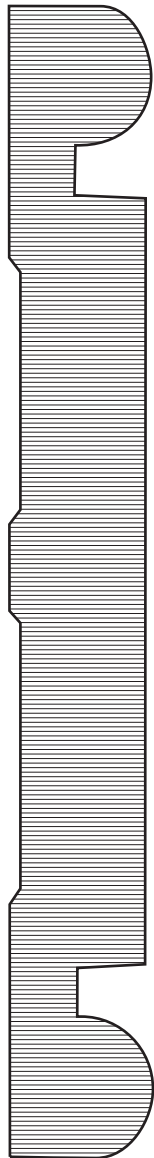

VM-8802  
1/2" x 5-3/8"



VM-9851  
1-5/8" x 4-3/8"

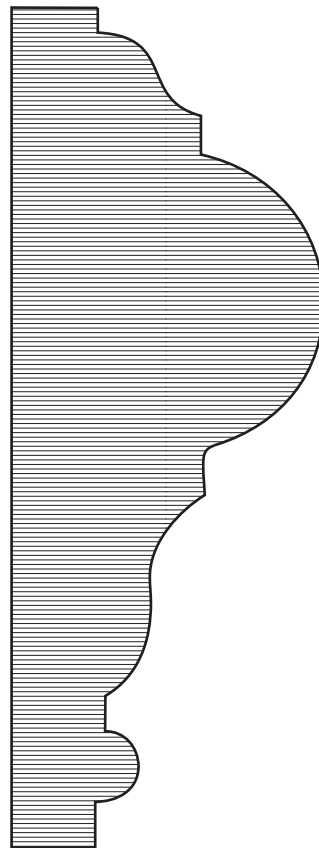

VM-8803  
1/2" x 4-1/8"



# Chair Rail

VM-1001  
3/4" x 2-3/4"

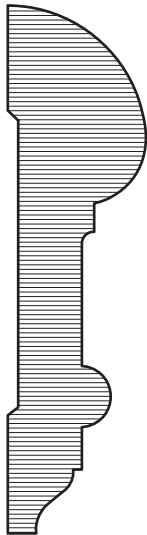

VM-8806  
1-1/16" x 2-1/2"



VM-9853  
1-1/8" x 3-3/16"



# Apron

VM-22  
3/4" x 3-1/2"

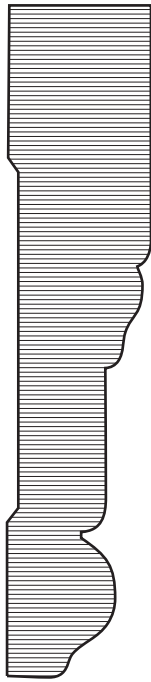

VM-3896  
3/4" x 2-1/2"

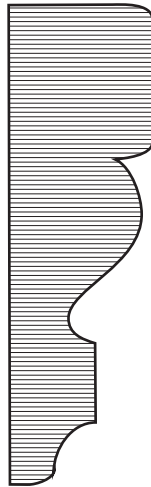

VM-2  
11/16" x 2-1/2"

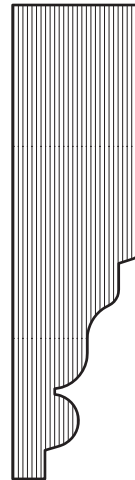



# Picture Mould

VM-273

5/8" x 1-3/4"

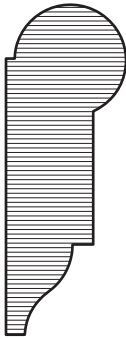

VM-295

1-1/8" x 1-3/4"

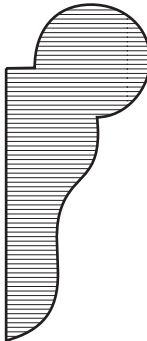

VM-296

3/4" x 1-13/16"

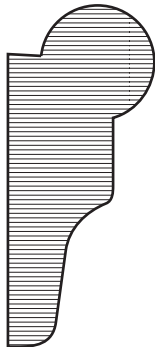

# Panel Mould

VM-894

3/4" x 7/8"

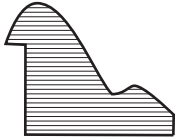

VM-896

3/4" x 1 - 1/8"

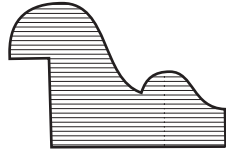

VM-899

5/8" x 3/4"

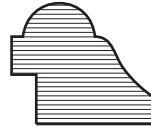

VM-789

3/4" x 1 - 1/4"

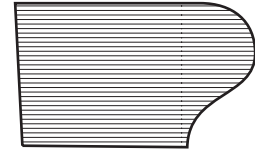

VM-1102

5/8" x 1 - 1/2"

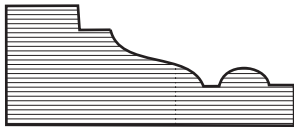

VM-1271

3/4" x 1 - 5/8"

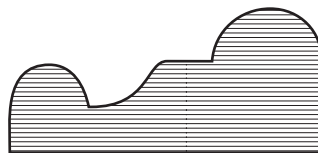

VM-1273

3/4" x 1 - 5/8"

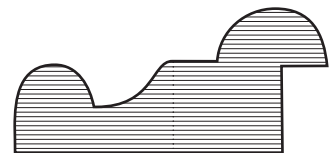

VM-1275

3/4" x 1 - 5/8"

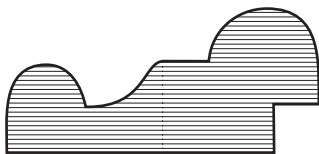

VM-1277

5/8" x 1 - 3/4"

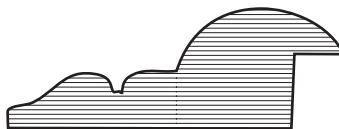

VM-1310

5/8" x 1 - 1/2"

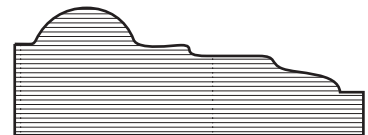

VM-1279

3/4" x 2 - 3/8"

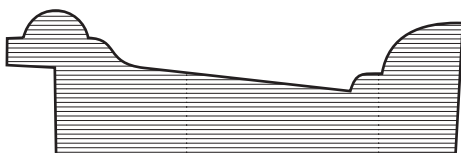

VM-1281

1" x 3"

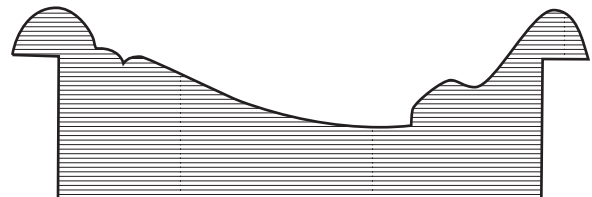

# Panel Mould

VM-1312

3/4" x 2 -1/4"

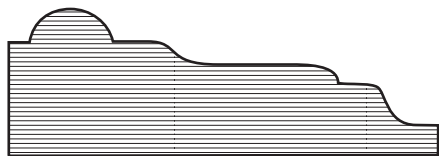

VM-1643

5/8" x 1-5/8"

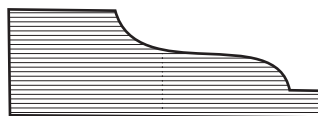

VM-1648

1/2" x 1-1/8"

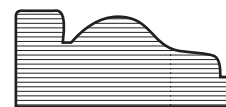

VM-1910

3/4" x 1-1/2"

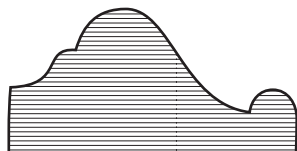

VM-1912

3/4" x 2"

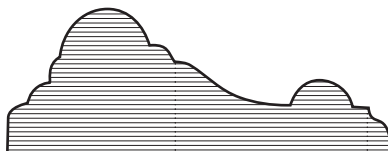

VM-7481

3/4" x 1-1/8"

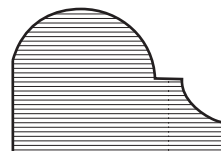

VM-9102

1-1/16" x 2-5/16"

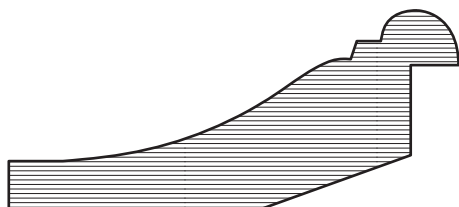

VM-9402

11/16" x 1-15/16"

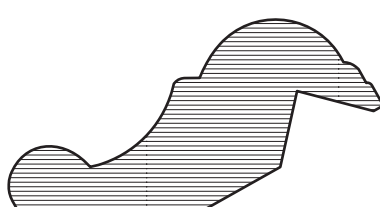

VM-42

1 -1/16" x 1- 5/8"

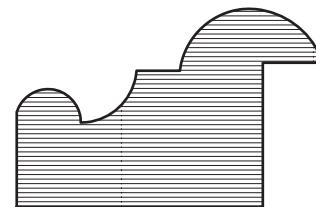

VM-9403

11/16" x 1-7/8"

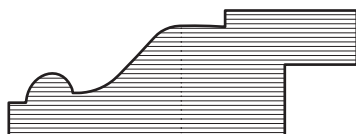

# Stop

VM-820  
3/8" x 7/8"

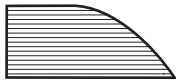

VM-842  
1/4" x 1-1/4"

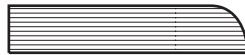

VM-34  
1/2" x 2"



VM-816  
3/8" x 1-3/8"

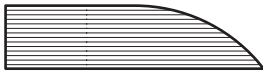

VM-935  
3/8" x 1-5/8"

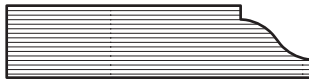

VM-936  
3/8" x 1-3/8"

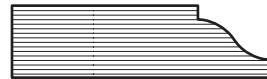

VM-938  
3/8" x 1-1/8"

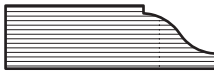

VM-940  
3/8" x 7/8"

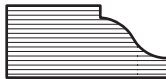

VM-941  
3/8" x 3/4"

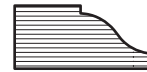

VM-32  
1/2" x 1-1/2"

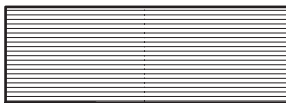

VM-33  
1/2" x 2"

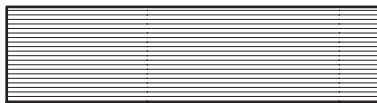

VM-151  
3/8" x 3/4"

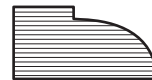

# Cove Mould

VM-14  
3/8" x 3/8"



VM-15  
1/2" x 1/2"



VM-97  
5/8" x 5/8"

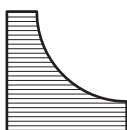

VM-98  
3/4" x 3/4"

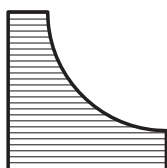

# Base Cap

VM-1330  
3/8" x 1/2"

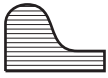

VM-174  
1/2" x 3/4"

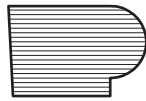

VM-172  
5/8" x 3/4"

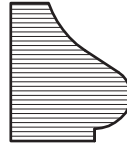

VM-272  
1/2" x 3/4"

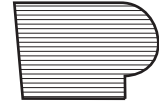

VM-162  
17/32" x 13/16"

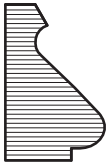

VM-163  
11/16" x 1-3/8"

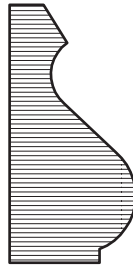

VM-169  
11/16" x 1-1/4"



VM-9923  
3/4" x 1-3/4"

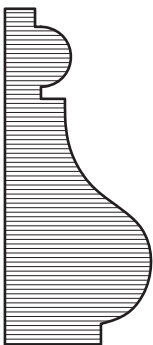

VM-4324  
1-1/16" x 1-5/8"

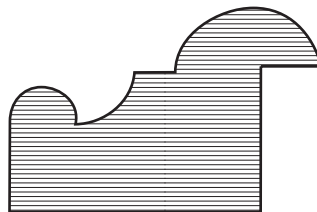

VM-1301  
3/4" x 1-3/4"

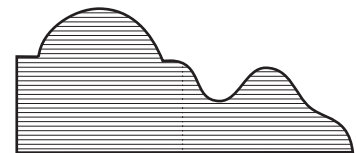

# Shoe Mould

VM-127  
1/2" x 3/4"

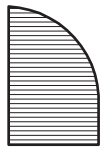

VM-128  
1/2" x 3/4"



VM-129  
1/2" x 1"



# Quarter Round

VM-111  
3/8" x 3/8"



VM-108  
1/2" x 1/2"



VM-107  
5/8" x 5/8"

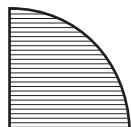

VM-105  
3/4" x 3/4"

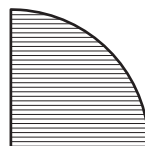

VM-103  
1-1/16" x 1-1/16"

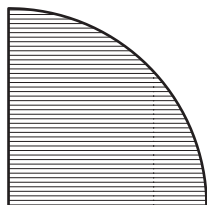



# Half Round

VM-124  
1/4" x 1/2"



VM-122  
3/8" x 3/4"

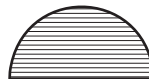

VM-222  
1/2" x 1"

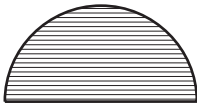

VM-9101  
3/4" x 1-1/2"

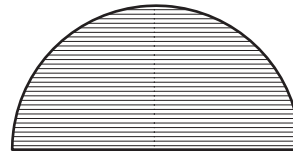

VM-9142  
1" x 2"

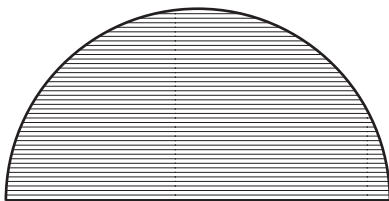

VM-9201  
1-1/2" x 3"

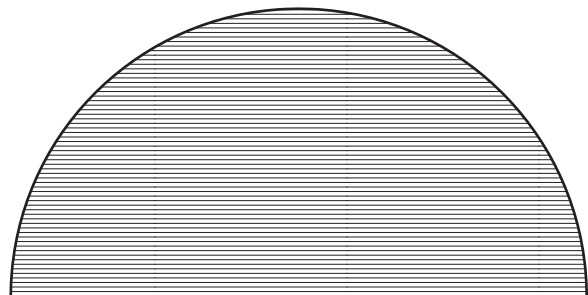

# Full Round

VM-233A

1-1/2" x 1-1/2"

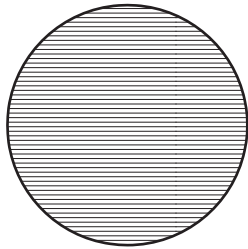

VM-233B

1-5/8" x 1-5/8"

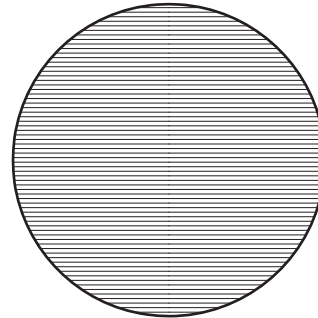

VM-233C

2" x 2"

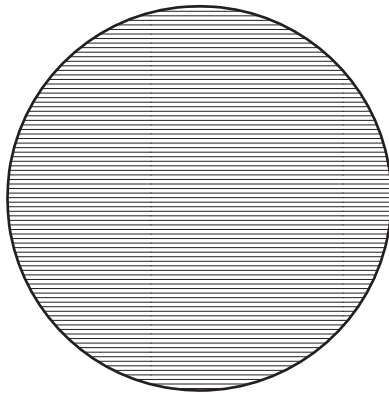

VM-233D

3" x 3"

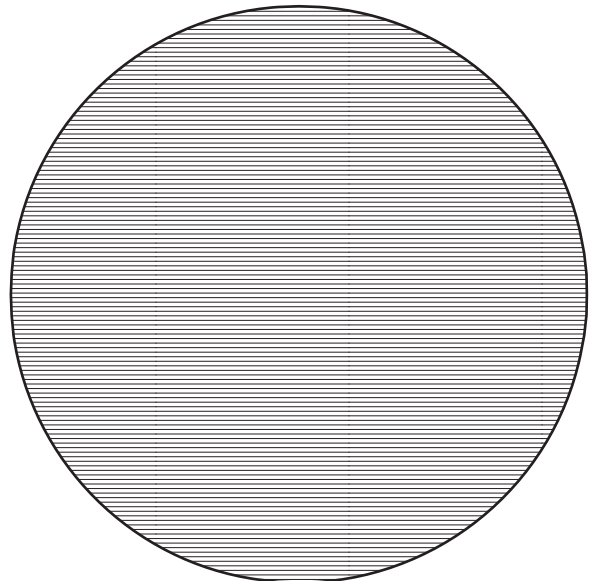

# Capital Mould

VM-1880

1-9/16" x 1-5/16"



VM-1881

1-1/4" x 1-7/8"

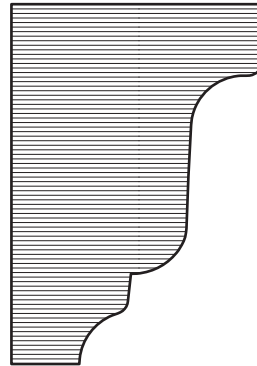

VM-1882

1-1/2" x 2-1/4"

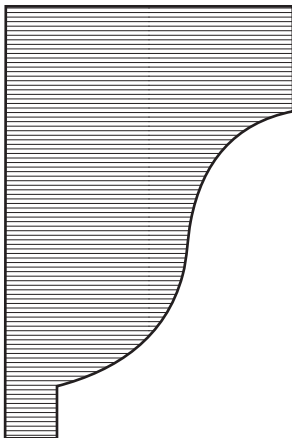

VM-1883

1-1/4" x 2"

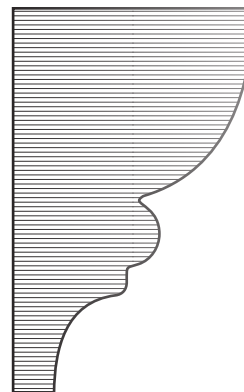

# Base Mould

VM-7483

1-5/16" x 1-15/16"

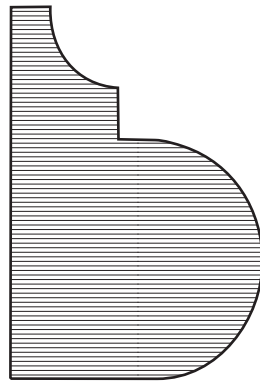

VM-9899

1-5/8" x 2-3/8"

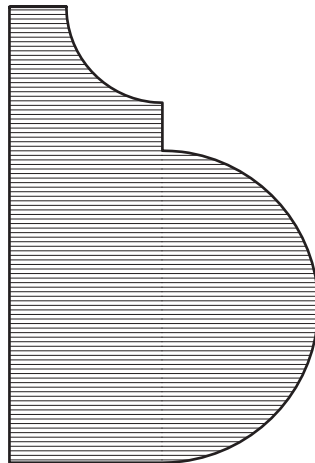

# Corner/Pencil

VM-206  
11/16" x 11/16"

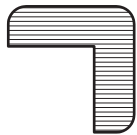

VM-8813  
1/2" x 1/2"



VM-205  
1-1/8" x 1-1/8"

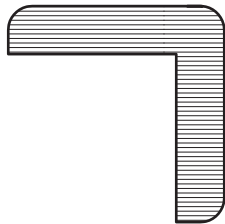

VM-8812  
3/4" x 3/4"

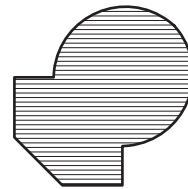

# Cabinet Mould

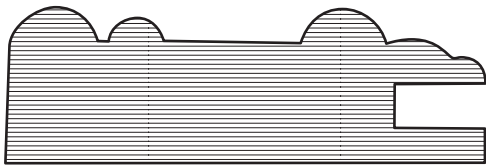

VM-6630  
13/16" x 2-1/2"

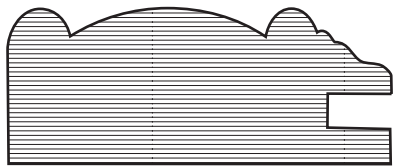

VM-6656  
13/16" x 2"

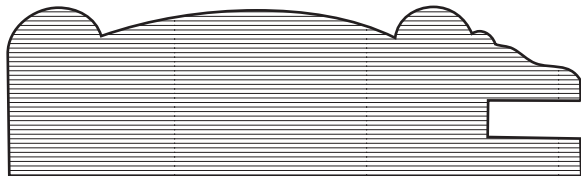

VM-6657  
13/16" x 3"

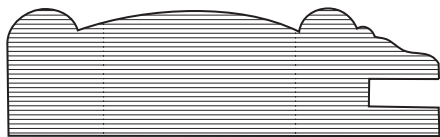

VM-6658  
13/16" x 2-1/4"

# Clover Mould

VM-8193  
9/16" x 1"

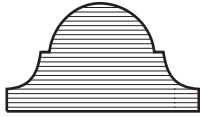

VM-8194  
3/4" x 1-1/4"

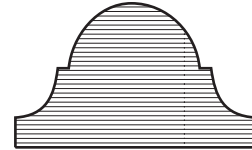

VM-8195  
3/4" x 1-11/16"

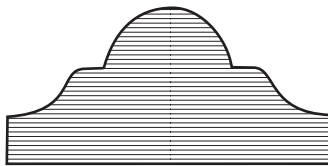

VM-8196  
3/4" x 1-5/8"

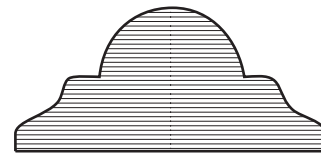

VM-8142  
11/16" x 1-1/4"

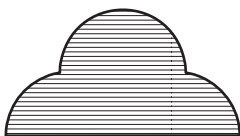

VM-8504  
3/4" x 1-1/4"

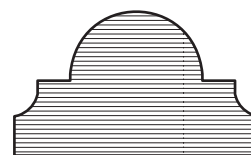

# Miscellaneous

VM-51

1-1/4" x 1-1/4"

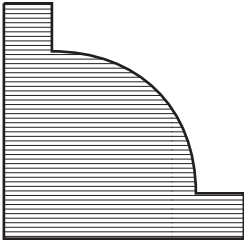

VM-53

5/8" x 5/8"

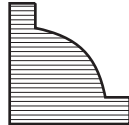

VM-1801

1 1/4" x 3/8"



VM-9960

1/2" x 1/2"



VM-5

3/4" x 1-1/8"

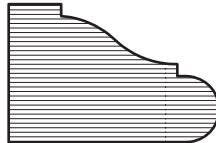

VM-9898

5/8" x 1"

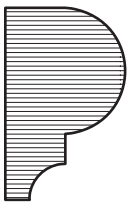

VM-142

1/4" x 3/4"



VM-995

3/4" x 3/4"

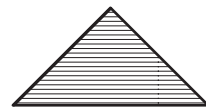



# Window Stool

VM-1365  
1" x 2-3/4"

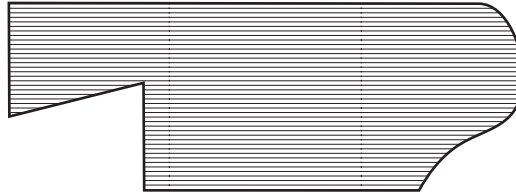

VM-39  
1 1/16" x 5-1/4"



VM-1194A  
1 1/16" x 2-3/4"

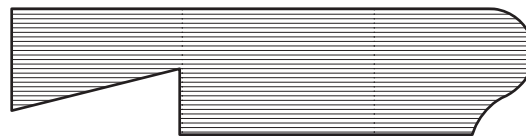

VM-1194B  
1 1/16" x 2-3/8"

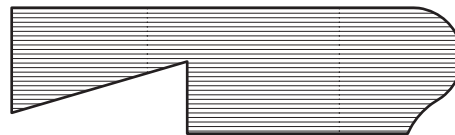

# Window Stool

VM-239  
1" x 5-1/2"

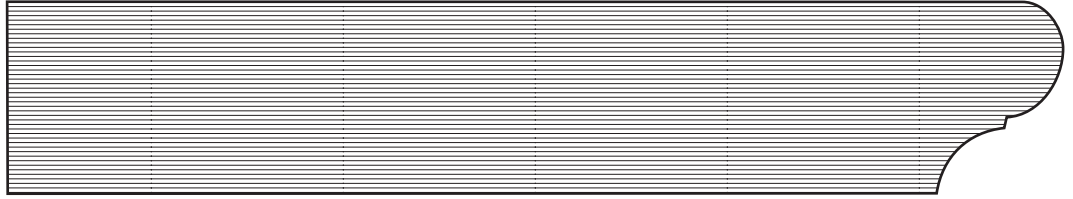

VM-1187  
3/4" x 2-3/4"

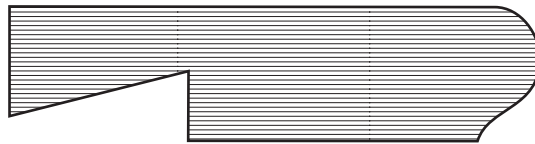

VM-1362A  
1" x 3-1/2"



VM-1362B  
1" x 5-1/2"



VM-1364  
3/4" x 3"

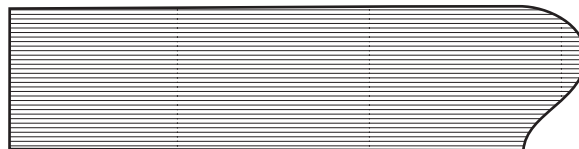

# Hand Rail

VM-1971  
1-3/4" x 4"

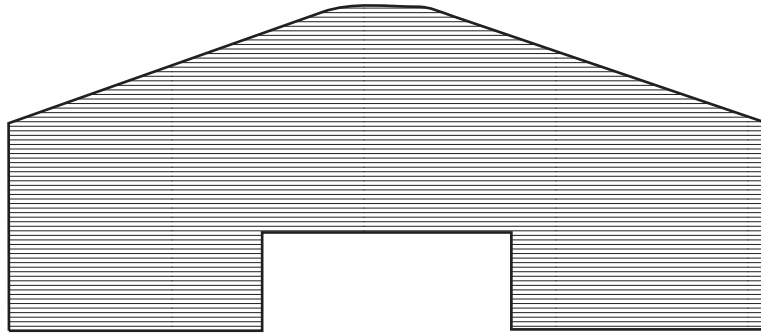

VM-1977  
1-1/2" x 5"

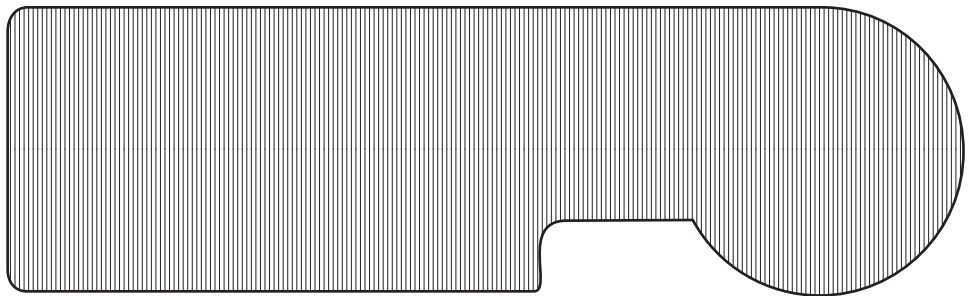

VM-2260  
1-3/8" x 2"

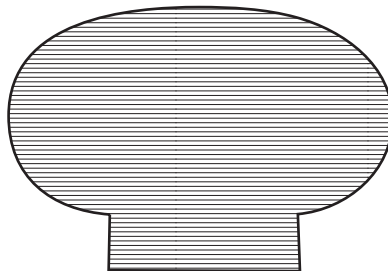

VM-2265  
2-1/4" x 2-3/8"

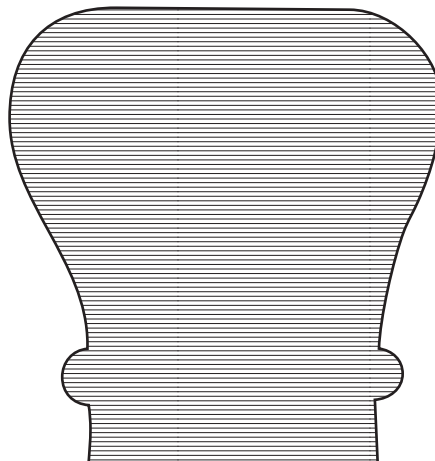

# Hand Rail

VM-231A  
1-3/8" x 1-1/2"

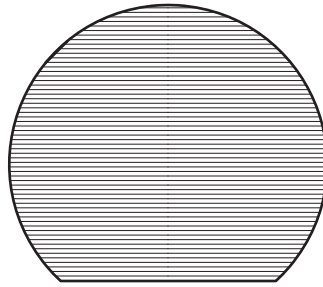

VM-231B  
1-1/2" x 1-5/8"

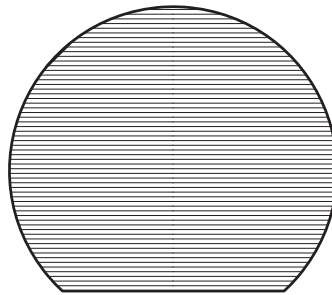

VM-231C  
1-7/8" x 2"

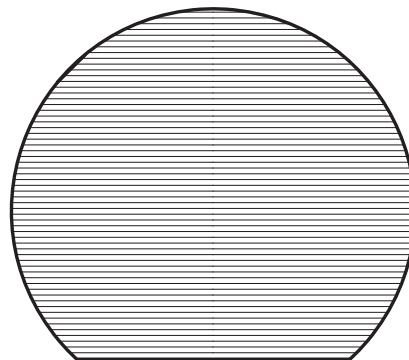

VM-231D  
2-7/8" x 3"

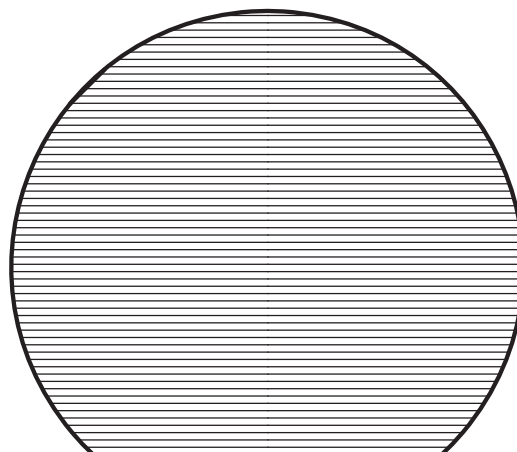

# Bar Rail

VM-8902  
1-1/2" x 6-3/8"

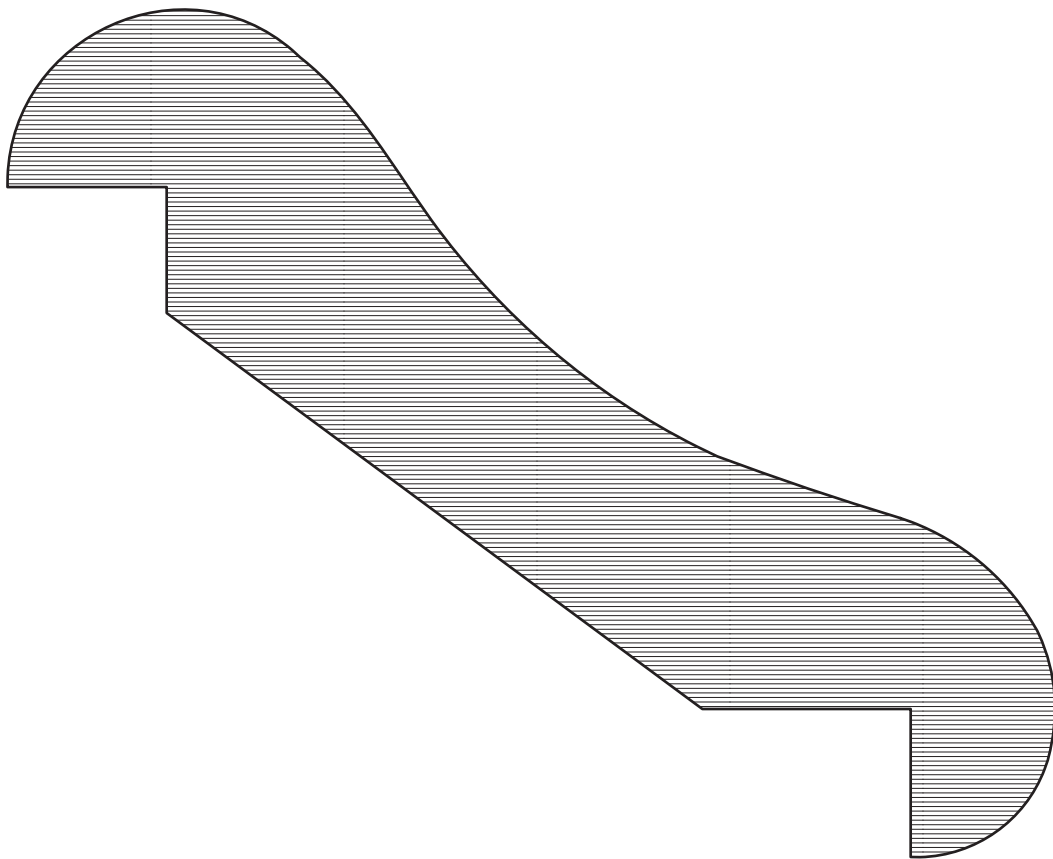

# Mantel Mould

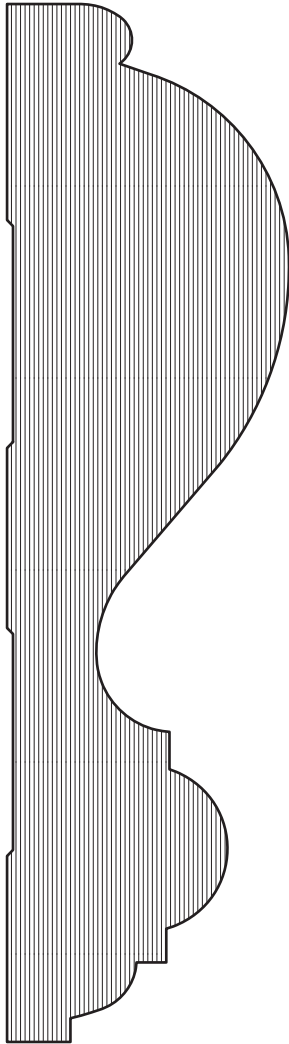

VM-20  
1-1/2" x 5-1/2"

# Box Cornice

VM-8903  
3/4" x 5-1/2"

VM-8904  
3/4" x 5-1/2"

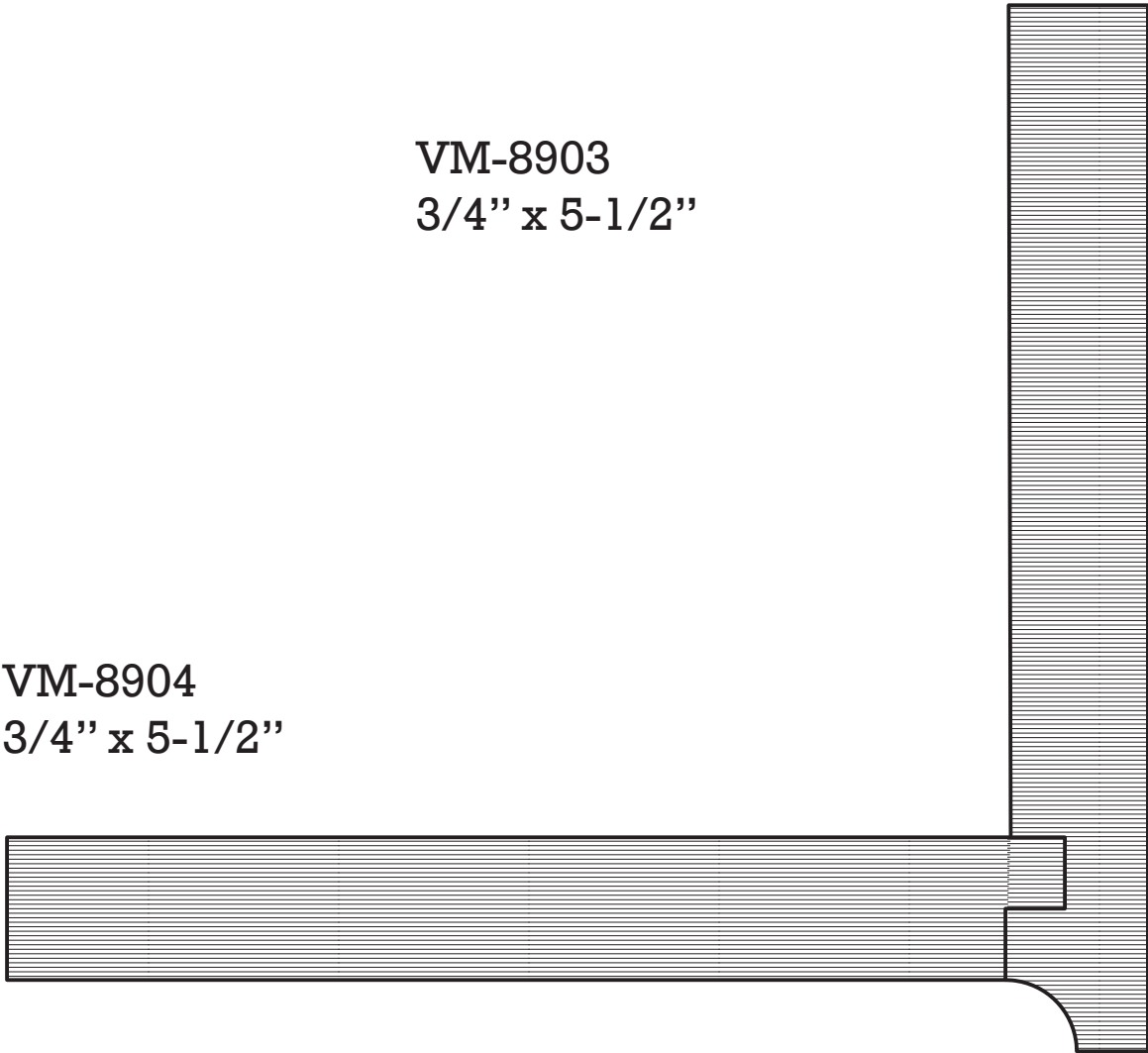

# Drip Cap

VM-187  
1-1/8" x 2"

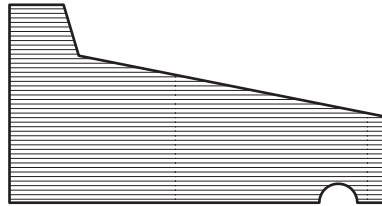

VM-188  
1-1/8" x 2-3/4"

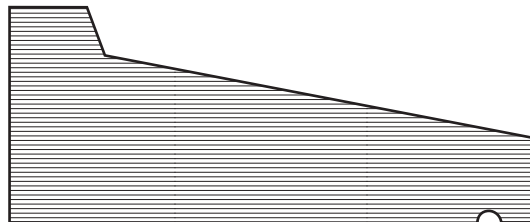

VM-189  
1-1/2" x 3-1/2"

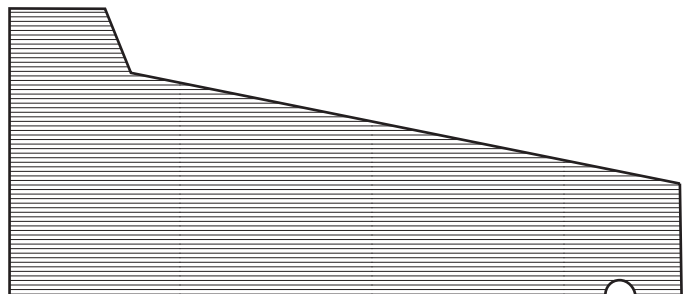



# Brick Mould

VM-1830  
1" x 1-3/4"

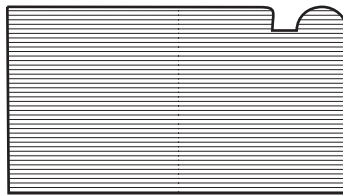

VM-180  
1-1/4" x 2"

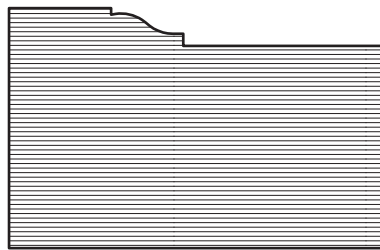

# Rake

VM-28  
3/4" x 3"

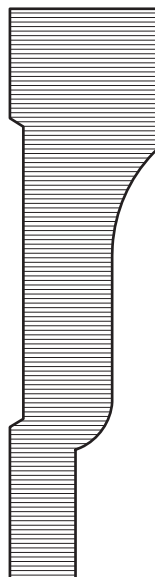

VM-29  
1-1/2" x 3-1/2"

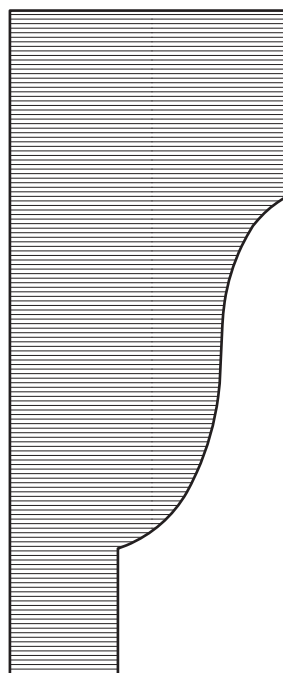

# Threshold

VM-3804  
3/4" x 2"

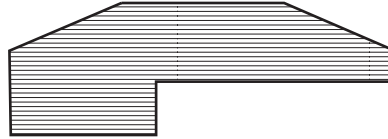

VM-3814  
3/8" x 1-1/2"



VM-41  
5/8" x 4-5/8"

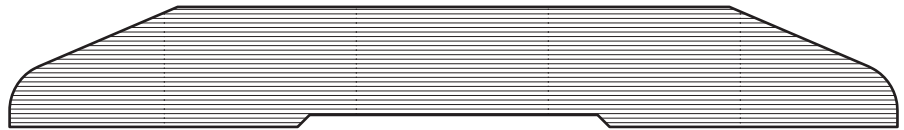

VM-45  
5/8" x 3-5/8"



VM-8278  
5/8" x 5-5/8"

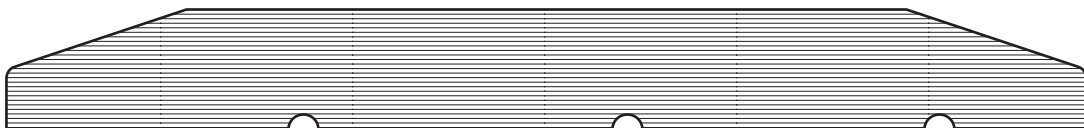

# T-Strip

VM-3810  
3/8" x 2"

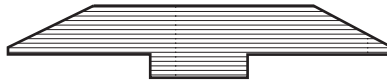

VM-3850  
5/8" x 2"

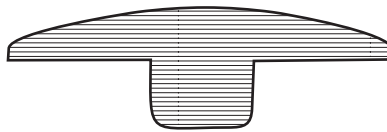

# Reducer

VM-3801  
1/2" x 2"

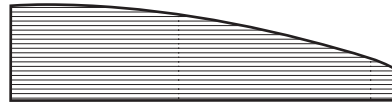

VM-3807  
3/4" x 2-1/4"

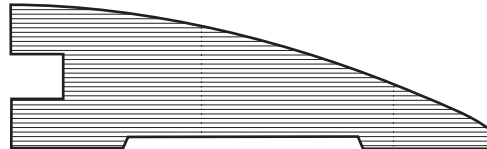

VM-3811  
3/8" x 1-1/2"

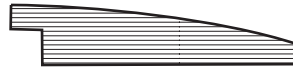

VM-3812  
3/8" x 1-1/2"



VM-3809  
1/4" x 1-1/2"



VM-3813  
3/8" x 1-1/2"

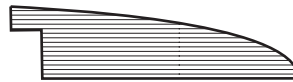

VM-3840  
3/4" x 2-1/4"

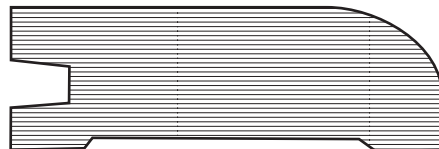

# Nosing/Tread

VM-24

1-1/16" x 1-1/4"

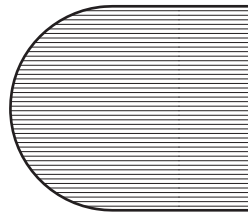

VM-23A

1-1/16" x 3-1/2"

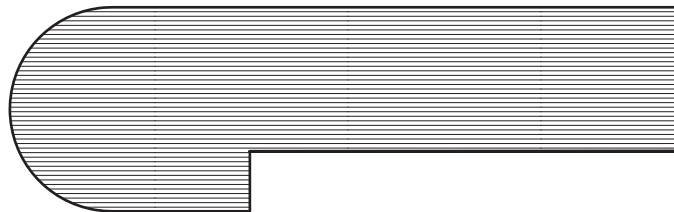

VM-23B

1-1/16" x 5-1/4"

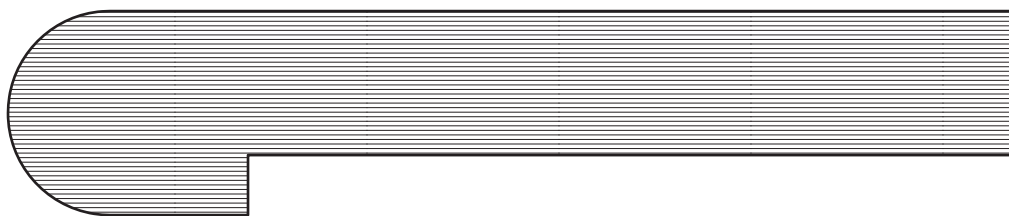

# Tread

VM-25  
1-1/16" x 11-1/2"



# S4S Lumber

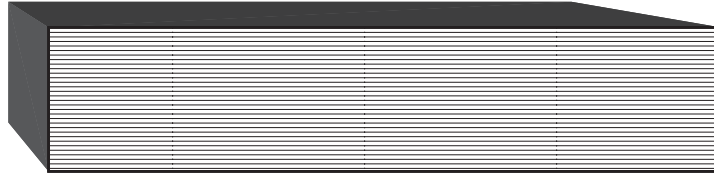

We can custom mill S4S (“Surfaced 4 Sides”) dimensional lumber to meet your needs; in the table below you will find those dimensions most commonly requested. Keep in mind that nominal sizes can also include 5/4 boards and 2” boards. Contact us for special requests – we have the ability to mill boards from 1/4” to 4” thick and up to 12” wide and anything in between. Custom sizes are our specialty!

Nominal Size	Actual Size
1” x 2”	3/4” x 1-1/2”
1” x 4”	3/4” x 3-1/2”
1” x 6”	3/4” x 5-1/2”
1” x 8”	3/4” x 7-1/4”
1” x 10”	3/4” x 9-1/4”
1” x 12”	3/4” x 11-1/4”
Custom	Custom

Additionally, for any S4S lumber orders, we can add rabbets or dados to meet your needs at no extra charge. Just let us know the details and we’ll be sure to get it done.



# Paneling

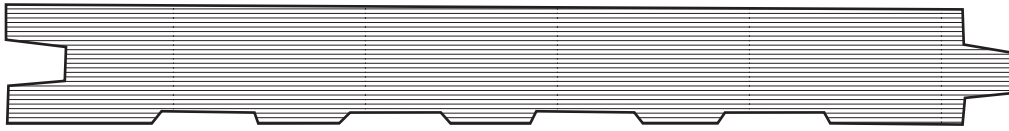

Similar to our S4S boards, we can custom mill Tongue & Groove and Ship Lap boards to meet your paneling or flooring needs; in the table below you will find those dimensions most commonly requested. Keep in mind that nominal sizes can also include 5/4 boards and 2" boards. Contact us for special requests – we have the ability to mill boards from 1/4" to 4" thick and up to 12" wide and anything in between. Custom sizes are our specialty!

*Note: the actual size of the boards includes the 1/4" tongue on one side. Because of the tongue, the face size of the boards is 1/4" smaller than the standard S4S size. But we can customize these dimensions to fit your needs.*

Nominal Size	Face Size	Actual Size (w/ tongue)
1" x 2"	3/4" x 1-1/4"	3/4" x 1-1/2"
1" x 4"	3/4" x 3-1/4"	3/4" x 3-1/2"
1" x 6"	3/4" x 5-1/4"	3/4" x 5-1/2"
1" x 8"	3/4" x 7"	3/4" x 7-1/4"
1" x 10"	3/4" x 9"	3/4" x 9-1/4"
1" x 12"	3/4" x 11"	3/4" x 11-1/4"
Custom	Custom	Custom

We can also mill varying sizes of the actual tongue/groove from 1/4" thick to 3/4" thick.

In addition to the standard tongue & groove, we can mill Nickel Gap Tongue & Groove, V-Tongue & Groove, Center-V-Tongue & Groove as well as any other custom profiles.

Ship lap boards can also be used for paneling / flooring purposes. These can be milled per common nominal or custom sizes with varying overlap dimensions to create the look you desire.

<b>Profile</b>	<b>Description</b>	<b>Page</b>
VM-2	Apron	40
VM-3	Casing	26
VM-4	Dentil Crown	14
VM-5	Cap Mould	56
VM-6	Casing	28
VM-7	Dentil Crown	14
VM-14	Cove Mould	45
VM-15	Cove Mould	45
VM-17	Crown	10
VM-18	Dentil Insert	14
VM-20	Mantel Mould	62
VM-22	Apron	40
VM-23A	Tread	70
VM-23B	Tread	70
VM-24	Nosing	70
VM-25	Tread	71
VM-27	Plinth Block	30
VM-28	Rake	66
VM-29	Rake	66
VM-32	Stop	44
VM-33	Stop	44
VM-34	Stop	44
VM-39	Window Stool	57
VM-41	Threshold	67
VM-42	Panel Mould	43
VM-45	Threshold	67
VM-47	Crown	10
VM-49	Crown	11
VM-51	Ovolo Mould	56
VM-53	Ovolo Mould	56
VM-60	Crown	11
VM-61	Crown	10
VM-70	Crown	10
VM-74	Crown	10
VM-85	Crown	11
VM-97	Cove Mould	45
VM-98	Cove Mould	45
VM-103	Quarter Round	48
VM-105	Quarter Round	48
VM-107	Quarter Round	48
VM-108	Quarter Round	48
VM-111	Quarter Round	48

<b>Profile</b>	<b>Description</b>	<b>Page</b>
VM-122	Half Round	49
VM-124	Half Round	49
VM-127	Shoe Mould	47
VM-128	Shoe Mould	47
VM-129	Shoe Mould	47
VM-142	Scribe Mould	56
VM-151	Stop	44
VM-161	Dentil Crown	15
VM-162	Base Cap	46
VM-163	Base Cap	46
VM-169	Base Cap	46
VM-172	Base Cap	46
VM-174	Base Cap	46
VM-180	Brick Mould	65
VM-187	Drip Cap	64
VM-188	Drip Cap	64
VM-189	Drip Cap	64
VM-197	Plinth Block	29
VM-205	Corner Mould	53
VM-206	Corner Mould	53
VM-220A	Mull Casing	34
VM-220B	Mull Casing	34
VM-220C	Mull Casing	34
VM-220D	Mull Casing	34
VM-222	Half Round	49
VM-231A	Hand Rail	60
VM-231B	Hand Rail	60
VM-231C	Hand Rail	60
VM-231D	Hand Rail	60
VM-233A	Full Round	50
VM-233B	Full Round	50
VM-233C	Full Round	50
VM-233D	Full Round	50
VM-239	Window Stool	58
VM-272	Base Cap	46
VM-273	Picture Mould	41
VM-280	Back Band	33
VM-281	Back Band	33
VM-282	Back Band	32
VM-283	Back Band	32
VM-284	Back Band	32
VM-285	Back Band	32

<b>Profile</b>	<b>Description</b>	<b>Page</b>
VM-286	Back Band	32
VM-288	Back Band	32
VM-295	Picture Mould	41
VM-296	Picture Mould	41
VM-325	Cove Crown	12
VM-358	Dentil Crown	15
VM-425	Cove Crown	12
VM-445	Casing	26
VM-482	Casing	24
VM-514	Dentil Crown	15
VM-525	Cove Crown	12
VM-618	Base Board	20
VM-620	Base Board	20
VM-623	Base Board	20
VM-625	Cove Crown	12
VM-627	Base Board	17
VM-629	Base Board	17
VM-642	Base Board	17
VM-707	Dentil Insert	14
VM-713	Base Board	20
VM-714	Base Board	17
VM-789	Panel Mould	42
VM-804	Chair Rail	36
VM-816	Stop	44
VM-820	Stop	44
VM-842	Stop	44
VM-894	Panel Mould	42
VM-896	Panel Mould	42
VM-899	Panel Mould	42
VM-935	Stop	44
VM-936	Stop	44
VM-938	Stop	44
VM-940	Stop	44
VM-941	Stop	44
VM-995	Chamfer	56
VM-1001	Chair Rail	39
VM-1102	Panel Mould	42
VM-1187	Window Stool	58
VM-1194A	Window Stool	57
VM-1194B	Window Stool	57
VM-1235	Crown	6
VM-1243	Crown	6

<b>Profile</b>	<b>Description</b>	<b>Page</b>
VM-1250	Crown	9
VM-1255	Crown	9
VM-1271	Panel Mould	42
VM-1273	Panel Mould	42
VM-1275	Panel Mould	42
VM-1277	Panel Mould	42
VM-1279	Panel Mould	42
VM-1281	Panel Mould	42
VM-1301	Base Cap	46
VM-1303	Chair Rail	36
VM-1305	Chair Rail	36
VM-1310	Panel Mould	42
VM-1312	Panel Mould	43
VM-1330	Base Cap	46
VM-1362A	Window Stool	58
VM-1362B	Window Stool	58
VM-1364	Window Stool	58
VM-1365	Window Stool	57
VM-1468	Crown	6
VM-1478	Crown	6
VM-1567	Chair Rail	36
VM-1643	Panel Mould	43
VM-1648	Panel Mould	43
VM-1801	Cap Mould	56
VM-1820	Back Band	32
VM-1830	Brick Mould	65
VM-1880	Capital Mould	51
VM-1881	Capital Mould	51
VM-1882	Capital Mould	51
VM-1883	Capital Mould	51
VM-1894	Crown	7
VM-1896	Crown	7
VM-1897	Crown	7
VM-1898	Crown	8
VM-1899	Crown	8
VM-1905	Chair Rail	36
VM-1910	Panel Mould	43
VM-1912	Panel Mould	43
VM-1971	Hand Rail	59
VM-1977	Hand Rail	59
VM-2200	Casing	21
VM-2201	Casing	21

<b>Profile</b>	<b>Description</b>	<b>Page</b>
VM-2202	Casing	21
VM-2260	Hand Rail	59
VM-2265	Hand Rail	59
VM-2369	Chair Rail	36
VM-2375	Chair Rail	36
VM-2399	Base Board	17
VM-2400	Plinth Block	29
VM-2700	Plinth Block	29
VM-2904	Chair Rail	37
VM-2907	Chair Rail	37
VM-2945	Cove Crown	13
VM-3300	Casing	21
VM-3320	Casing	21
VM-3325	Plinth Block	29
VM-3372	Base Board	18
VM-3374	Base Board	18
VM-3376	Base Board	18
VM-3378	Base Board	18
VM-3462	Base Board	19
VM-3472	Base Board	19
VM-3482	Base Board	19
VM-3678	Base Board	19
VM-3700	Plinth Block	30
VM-3801	Reducer	69
VM-3804	Threshold	67
VM-3807	Reducer	69
VM-3809	Reducer	69
VM-3810	T-Strip	68
VM-3811	Reducer	69
VM-3812	Reducer	69
VM-3813	Reducer	69
VM-3814	Threshold	67
VM-3840	Reducer	69
VM-3850	T-Strip	68
VM-3896	Apron	40
VM-4248	Pilaster	35
VM-4324	Base Cap	46
VM-4448	Pilaster	35
VM-4710	Casing	22
VM-8904	Box Cornice	63
VM-8905	Casing	26
VM-9001A	Crown	9

<b>Profile</b>	<b>Description</b>	<b>Page</b>
VM-9001B	Crown	9
VM-9002	Casing	27
VM-9003	Casing	27
VM-9009	Casing	24
VM-9101	Half Round	49
VM-9102	Panel Mould	43
VM-9142	Half Round	49
VM-9201	Half Round	49
VM-9304	Cove Crown	13
VM-9402	Panel Mould	43
VM-9403	Panel Mould	43
VM-9800	Plinth Block	30
VM-9821	Casing	23
VM-9823A	Casing	24
VM-9823B	Casing	24
VM-9825	Casing	28
VM-9827	Casing	28
VM-9837A	Casing	28
VM-9837B	Casing	28
VM-9848	Mull Casing	34
VM-9851	Chair Rail	38
VM-9853	Chair Rail	39
VM-9864	Mull Casing	34
VM-9865	Mull Casing	34
VM-9880	Cove Crown	13
VM-9898	Neck Mould	56
VM-9899	Base Mould	52
VM-9901	Casing	26
VM-9902	Back Band	33
VM-9917	Crown	11
VM-9923	Base Cap	46
VM-9929	Plinth Block	31
VM-9939	Casing	23
VM-9940	Back Band	33
VM-9943	Crown	11
VM-9947	Casing	24
VM-9960	Cap Mould	56
--	Dentil Mould	16
--	Dentil Mould	16
--	S4S Lumber	72
--	Paneling	73
--	--	--



**NOTES**

Lined writing area with 21 horizontal lines.







